

The Boat-coffins and Single-log Coffins in Shangye Street, Chengdu, Sichuan

Chengdu Municipal Institute of Antiquity and Archaeology

Keywords: massive tomb boat-coffins early Warring States period lacquer ware

The boat-coffins and single-log coffins are located in No. 58, Shangye 商业 Street, within the first ring road of Chengdu 成都 downtown area. From July 2000 to the beginning of 2001 Chengdu Municipal Institute of Antiquity and Archaeology made an excavation of this site and determined it to be a massive tomb of the early Warring States period. It was selected as one of the top ten great archaeological discoveries in China in 2000 and declared by the State Council as a historical site of the fifth group under special protection within China in July 2001.

I. A Survey of the Tomb

Excavation reveals that it is a large rectangular earthen shaft tomb with multiple burials, having neither passage nor sealed earth. Peculiar in structure, this massive tomb may be divided into two parts: tomb pit and on-the-ground structure.

1. Tomb pit. It is about 30.5 m long, 20.3 m wide and 2.5 m deep, with an area of about 620 sq m. It is constructed at an angle of 240 degrees with straight walls and flat bottom. The fill inside the pit surrounding every coffin is comparatively pure livid clay and may be divided into three layers from upper to the bottom. For this reason, the wood of the coffin and the burial accessories such as the lacquered wooden wares were all preserved in a fairly good condition. The crossties under coffins are arrayed neatly in about 15 rows. They are almost of the same diameter, but differ in length.

The tomb had suffered many severe robbery and destruction. The earliest destruction occurred as early as in the Han Dynasty at least. It is estimated that there should be more than 35 coffins in this tomb had there been no destruction done to it. Presently there are 17 sets of wooden coffins (Nos. 1–17), of which 4 are big ones,

13 are small ones. The coffins are all arrayed in parallel in the same direction as the tomb pit. The fill indicates that all the coffins are placed in the pit sequentially once for all. There is a large rectangular lump of wood in the middle of the pit slightly to the south. This lump of wood roughly serves as the boundary separating the tomb pit into two sections: the front and the back section. In the back section of the pit, i.e. north to the lump of wood, are mainly placed large coffins, including coffins Nos. 1, 2, and 12 (the remaining vertical pillars on both sides of the coffins indicate that between coffins No. 1 and No. 12 there ought to be 4 other large coffins). On the two sides of large coffins are set small ones. In the front section of the tomb pit, due to grave destruction, only several small coffins remain. Judged from the present situation, no large coffins were placed in this section except coffin No. 13, which is located on the east section of the pit, east to the lump of wood. In the center of the tomb pit, between the lump of wood and the large coffin there are eight bar-shaped small log on the crossties, the front of most of which are under the big log while the backs of which reach the coffin. They are neatly arrayed and regularly distanced. According to scholarly estimation, the arrangement of them also has something to do with the structure of the tomb, but many of which are cut (Figs. 1 and 2).

2. The ground construction. The present ground construction of the tomb is about 38.5 m long and 20.5 m wide and may be divided into the forepart and the back part. It ought to have been built after the filling of the tomb pit, the digging of the groove and the paving of *difu*. Presently the remains of this ground structure are the groove and some wooden parts distributed in a certain shape in accordance to some rules, such as the hollow pedestal and the bar-shaped *difu* with tenons on

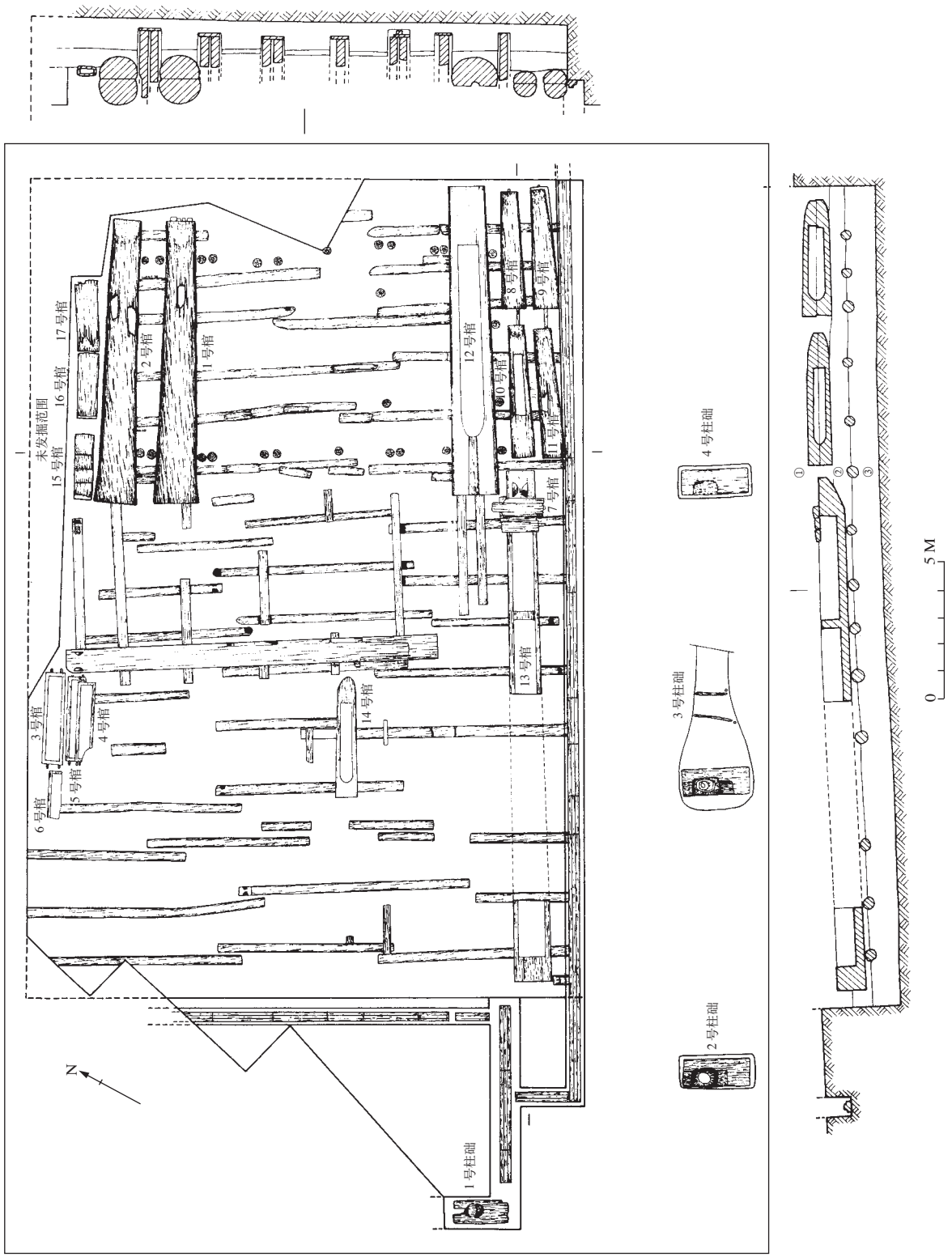

Fig. 1 Plan and elevation of the boat-coffins and single-log coffins in Shangye Street

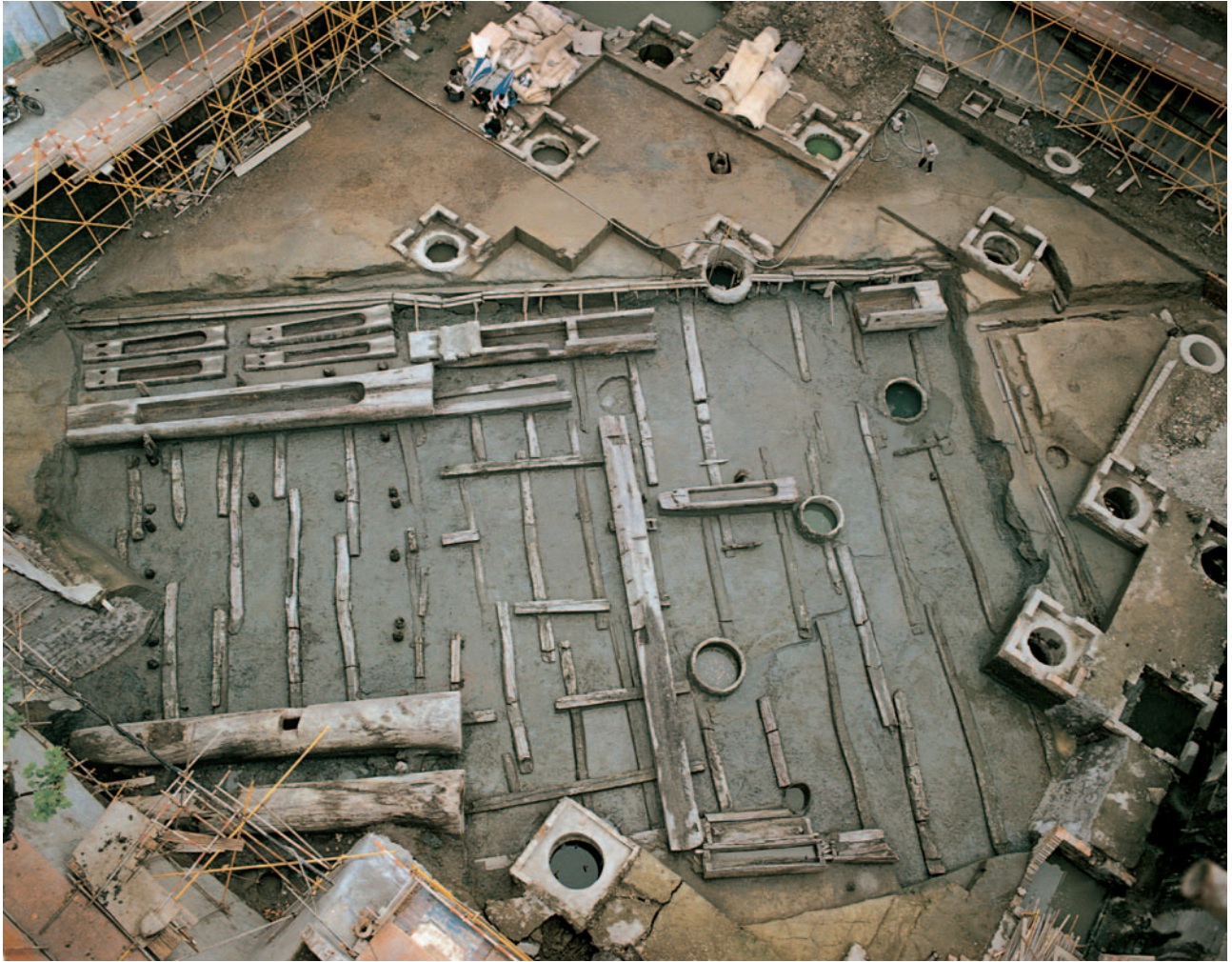

Fig. 2 Panorama view of the boat-coffins and single-log coffins in Shangye Street

them (these *difu* ought to be part of the footing of the wall of the whole ground structure).

The forepart of this ground structure is located to the south of the tomb pit, with rectangular groove and *difu* about 15 m from east to west and 7.5 m from north to south. On the east and west side of it is respectively a room of about 3.5 m long and 2.5 m wide, i.e. the wing of the ground structure (due to limitation of the site, the west side was not excavated). *Difu* was placed on the bottom of the groove digged previously. In the south of the structure a wooden pedestal (No. 1) was discovered, with a wooden board underneath to bear weight. The pedestal was actually a log with a round hole in the center and simply processed circumference.

The back of the ground structure was exactly located above the tomb pit and roughly of the same size as that. The bar-shaped *difu* is distributed around the tomb pit, yet only along the eastern side were they discovered, in connection with the *difu* on the east most

side of the forepart of the ground structure. The northern end still extends further. Yet due to limitation of the excavation area, no digging was made there. As in the previous case, the *difu* in the back structure was also placed on the bottom of the groove, which had to be prepared early. Apart from these, pedestals Nos. 2–4 were also discovered to the east of the tomb pit, similar with pedestal No. 1 in shape, yet somewhat larger in scale. They are roughly arrayed linearly and also belong to the ground structure; only pedestal No. 3 is still in comparatively good condition.

II. Coffins

There are 17 coffins unearthed from the tomb pit altogether, composed of ladder and coffin body. According to examination they are all made of machilol wood. Among them coffins Nos. 1, 2, 8–14 are all boat-coffins. The process of making boat-coffins is as follows: cut off one-third of a machilol log and hollow out the log

so that it shapes like a canoe. The cabin of the canoe is actually the coffin chamber. The inner side of the cabin has undergone regular trimming while the outer side has only undergone slight trimming. In all cases except coffin No. 12, the boat-coffins all turn upwards slightly at the front end of the coffin by having the front end scraped upwards and shaped like the boat bow. On either side of the bow is a semicircular hole going slantingly to the bottom of the coffin. The ladger is made in the same way and appear the same in structure as that of the coffin body. The two parts clasp with each other and form the boat-coffin. Of all the boat-coffins five are small ones and four large ones. Based on their structure, they may be divided into four types (Figs. 3–6).

The other eight coffins are all single-log coffins, whose ladger and body are also made of a single log. Yet it differs enormously from boat-coffins in structure and occupies a relatively small volume. Coffins Nos. 3–7 may be called rectangular coffins, on whose four corners are four handles attached to the coffin body. It is flat on bottom and slightly curves on the two sides. As for the ladger, it curves slightly on the back and has handles at the four corners. The ladger clasps with the coffin body through snap tenons (Fig. 7). Coffins Nos. 15–17 may be called box-shaped coffin due to its shape and is even smaller than the single-log coffin. The process of making a box-shaped coffin is extremely simple: the body is also made by hollowing out a log, only on the two ends of the coffin are two end panels respectively, which connect with the coffin body through snap tenons. The ladger is a piece of flat wooden board the same size as the mouth of the coffin and covers the coffin body flatly.

Most of the 17 coffins had undergone different degrees of disturbance and robbery and only seven are comparatively well preserved. Of the nine boat-coffins, Nos. 9 and 11 are for storage of burial accessories and so contain no human skeletons; coffins Nos. 12 and 13 also produced no human bones due to severe destruction. The rest of the five boat-coffins are all discovered containing human skeletons, one occupant in one coffin. Due to severe disturbance the burial state of coffins Nos. 1 and 10 can no longer be determined clearly. As for the rest, coffin No. 8 suffered no robbery and can be clearly defined as secondary burial; coffins Nos. 2 and 14 suffered no severe disturbance and so can be discerned as secondary burial. The skeletons inside those coffins had suffered loss of different degrees, yet the skulls are all there. No first burials are discovered in the boat-

coffins. Contrary to this, of the eight single-log coffins, the burials in the five coffins from which human skeletons are discovered are all first burials in extended supine position (due to severe destruction no human skeletons are discovered from coffins Nos. 6, 7, and 17).

III. Burial Accessories

The burial accessories unearthed from the nine boat-coffins are very rich, including pottery, bronze, lacquer, and bamboo-wooden wares. As for pottery, the items include double-eared *weng*-urns, flat-bottomed *guan*-jars, *fu*-cauldrons with round bottom, ring-foot *dou*-pedestal stands, *zhan*-cups with pointed bottom, and vessel lids. The excavation indicates that the lids are used to match the double-eared *weng*-urns and flat-bottomed *guan*-jars since their quantity is far larger than other items. From each double-eared *weng*-urn, a small amount of corn dregs and fruit cores are discovered. The bronze ware is rather few in number as well as in variety and no large bronze items are discovered from the coffins. Some are weapons such as spears, lances, fells and scrapers, of which some are only rough funeral objects (Fig. 8). Seals are also discovered and on some bronze ware are carved signs. Large quantities of fine lacquer-wooden ware are also retrieved from the coffins, such as *erbei*-eared cups, plates, boxes, *gui*-container, chopping boards, supports, combs, and many lacquer-wooden parts. Apart from these, there are also woven items of bamboo, such as mat, small basket, and basket. From the eight single-log coffins, only pottery and bronze are retrieved. The pottery wares are not large in quantity and no double-eared *weng*-urns or flat-bottomed *guan*-jars among the pottery items. The unearthed items include *weng*-urns, *zhan*-cups with pointed bottom, round-bottomed *fu*-cauldrons, ring-foot *dou*-pedestal bowls, and lids. The bronze items are even fewer, i.e., with only one belt buckle and one scraper.

The pottery items are all gray pottery mixed with fine sand, made through clay-strip forming technique and turn-table trimming. The decorative patterns on the pottery are rather simple, including cord patterns, basket patterns, and line patterns. Cord patterns are mainly distributed on the round-bottomed *fu*-cauldrons while the basket patterns mainly on double-eared *guan*-jars. Many pottery items, such as double-eared *weng*-urns and lids, are rather peculiar in shape and bear no traces of usage. Hence it is estimated that they are merely funeral objects for the occasion of burials only (Figs. 9–13). As for the unearthed lacquer-wooden wares, they not

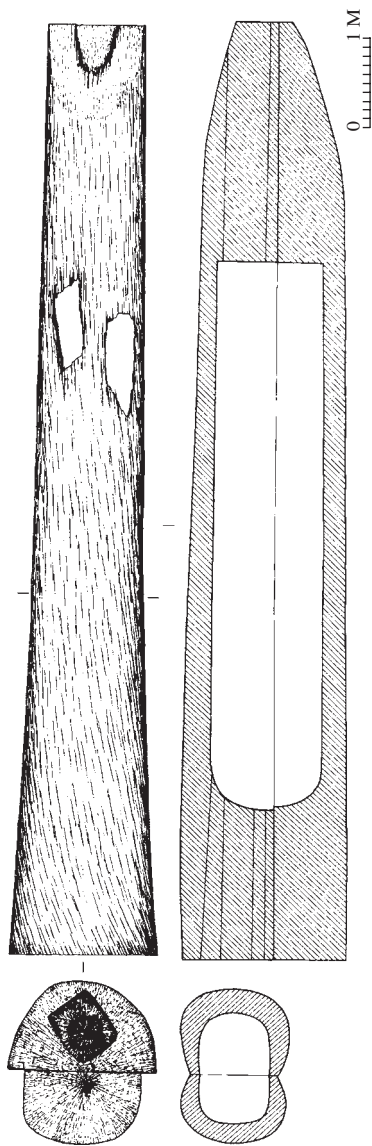

Fig. 3 Plan and elevation of coffin No. 2

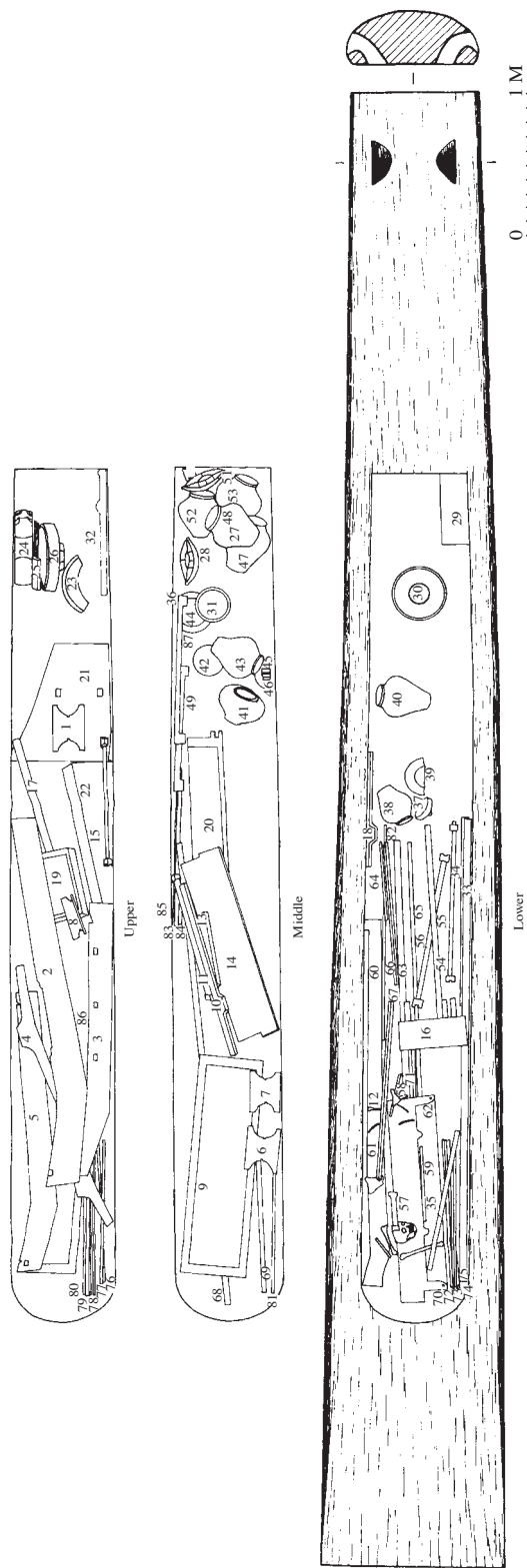

Fig. 4 Plan of coffin No. 2

Upper: funeral objects in the first layer

Middle: funeral objects in the second layer

Lower: funeral objects in the third layer

1-26, 28-30, 32-36, 39, 45, 49-51, 54-70, 72-86. lacquer and wooden objects 27, 38, 40, 41, 43, 47, 52, 53, 87. pottery double handled weng-ums 31, 37, 42, 44, 46, 48. type A pottery lids 71. bronze ware

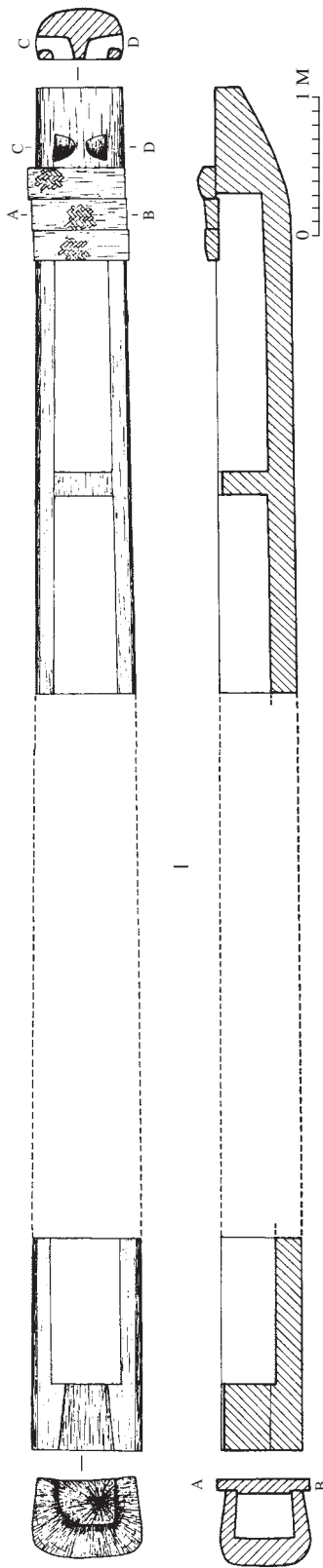

Fig. 5 Plan and elevation of coffin No. 13

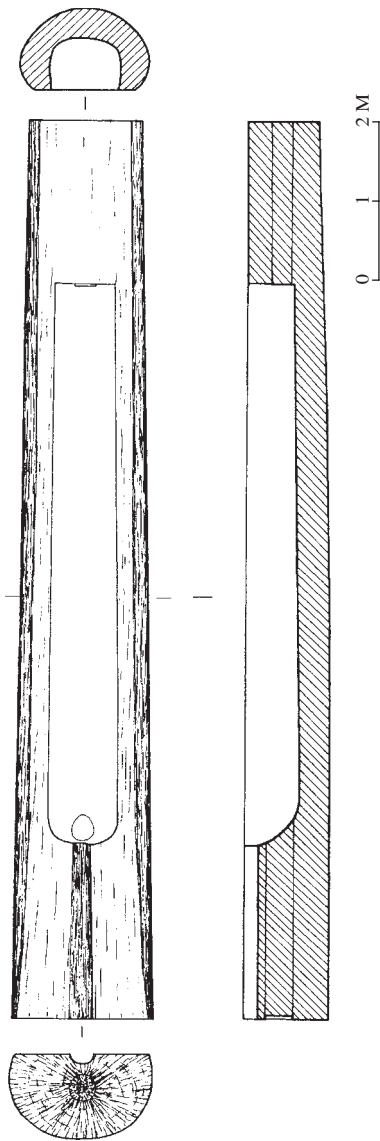

Fig. 6 Plan and elevation of coffin No. 12

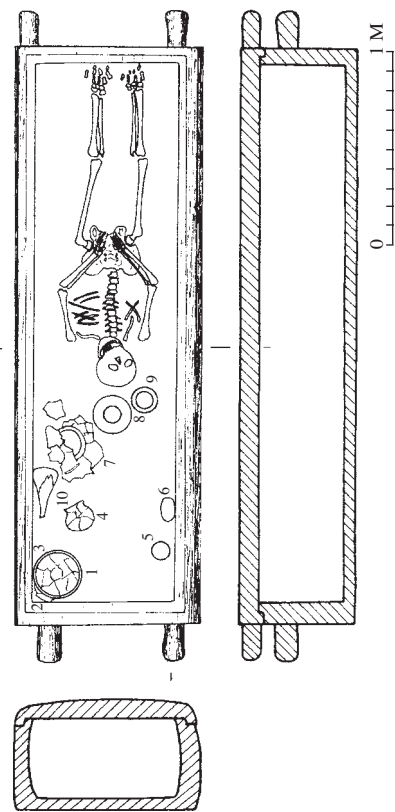

Fig. 7 Plan and elevation of coffin No. 5

1. type C pottery lid 2. pottery lid 3, 5, 6. pointed bottomed pottery cups 4, 8. type B round bottomed pottery *fit*-cauldrons 7. pottery *weng*-urn 9. type A round bottomed pottery *fit*-cauldron 10. gourd shaped *sheng*-musical instrument

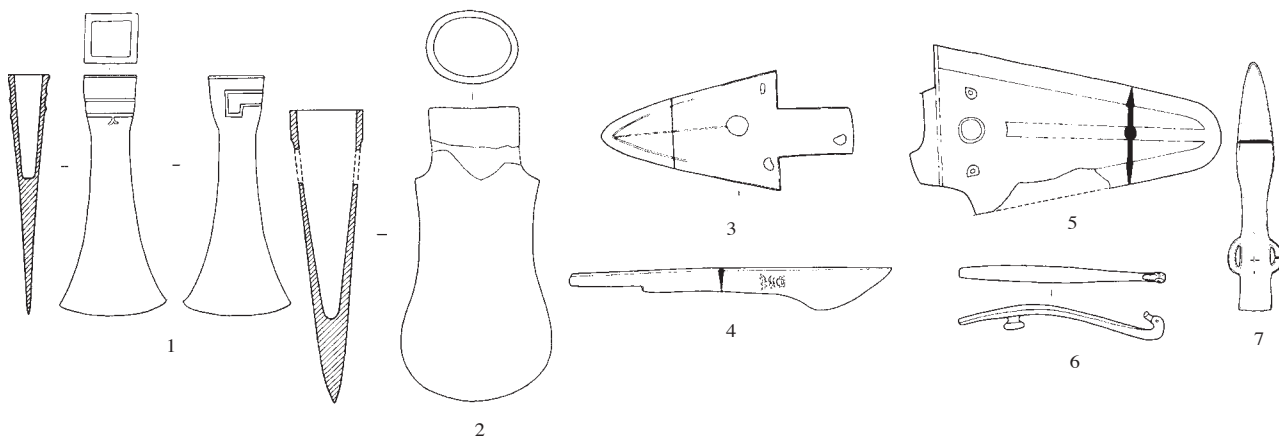

Fig. 8 Bronze objects

1. axe (coffin No. 1:27) 2. *yue*-battle axe (looting hole of coffin No. 1:2) 3, 5. *ge*-dagger-axes (coffin No. 1:50, looting hole of coffin No. 1) 4. scraper (coffin No. 1:52) 6. belt hook (coffin No. 3:1) 7. spear (coffin No. 1:49) (Scale: 1/3)



Fig. 9 Pottery *weng*-urn with double ears (coffin No. 9:1) and type A lid (coffin No. 9:18)



Fig. 10 Type A pottery *guan*-jar with flat bottom (coffin No.1:3) and type B lid (coffin No. 1:8)



Fig. 11 Type B pottery *fu*-cauldron with round bottom (coffin No. 11:17)



Fig. 12 Type A pottery *fu*-cauldron with round bottom (coffin No. 5:9)



Fig. 13 Pottery *dou*-pedestal bowl (coffin No. 5:2)

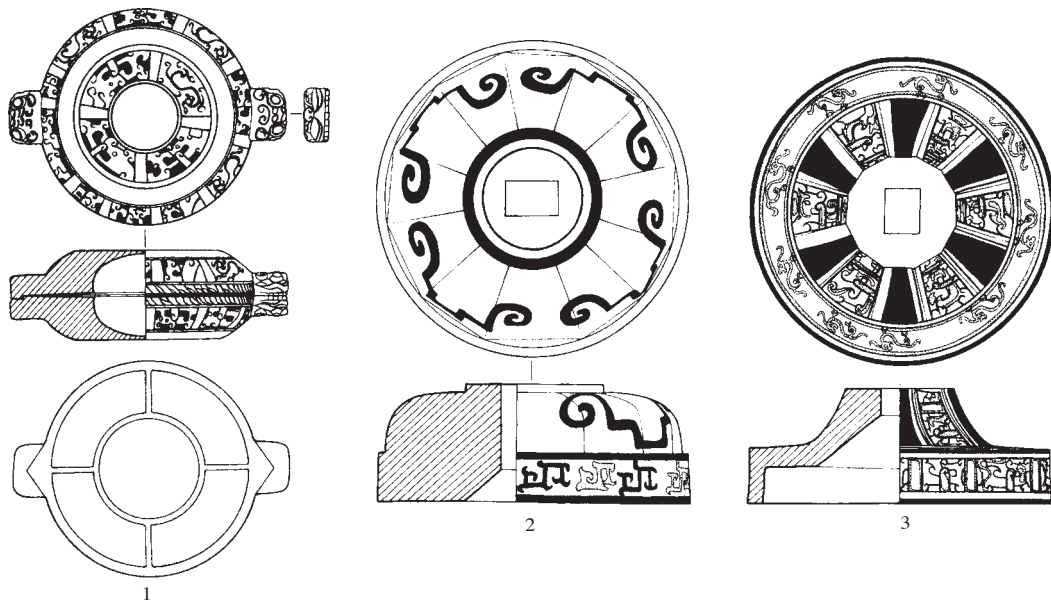

Fig. 14 Lacquer wares

1. box (coffin No. 2:28) 2. type A stand (coffin No. 11:19) 3. type B stand (coffin No. 1:41) (Scales: 1, 3. 1/10; 2. 1/5)

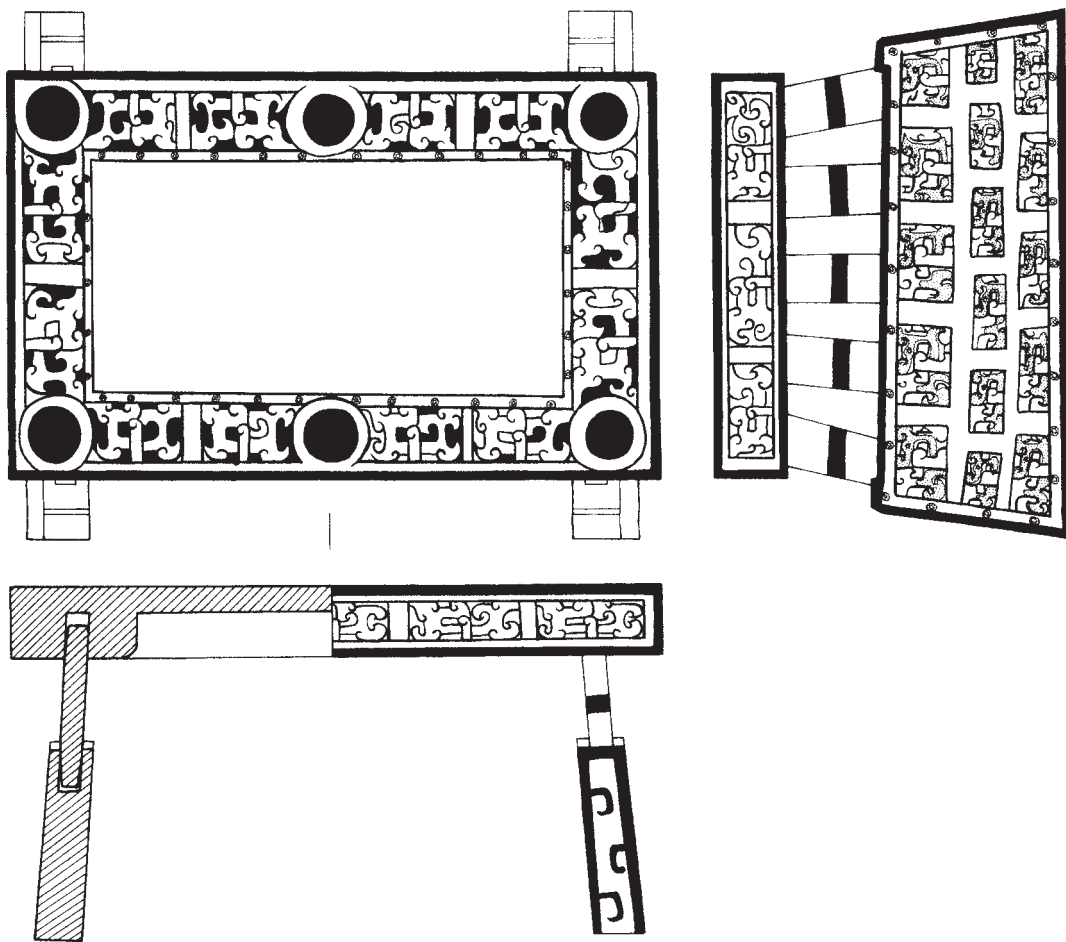

Fig. 15 Type A lacquer ritual board

Top (coffin No. 2:19) Left leg (coffin No. 9:14) (Scale: 1/8)

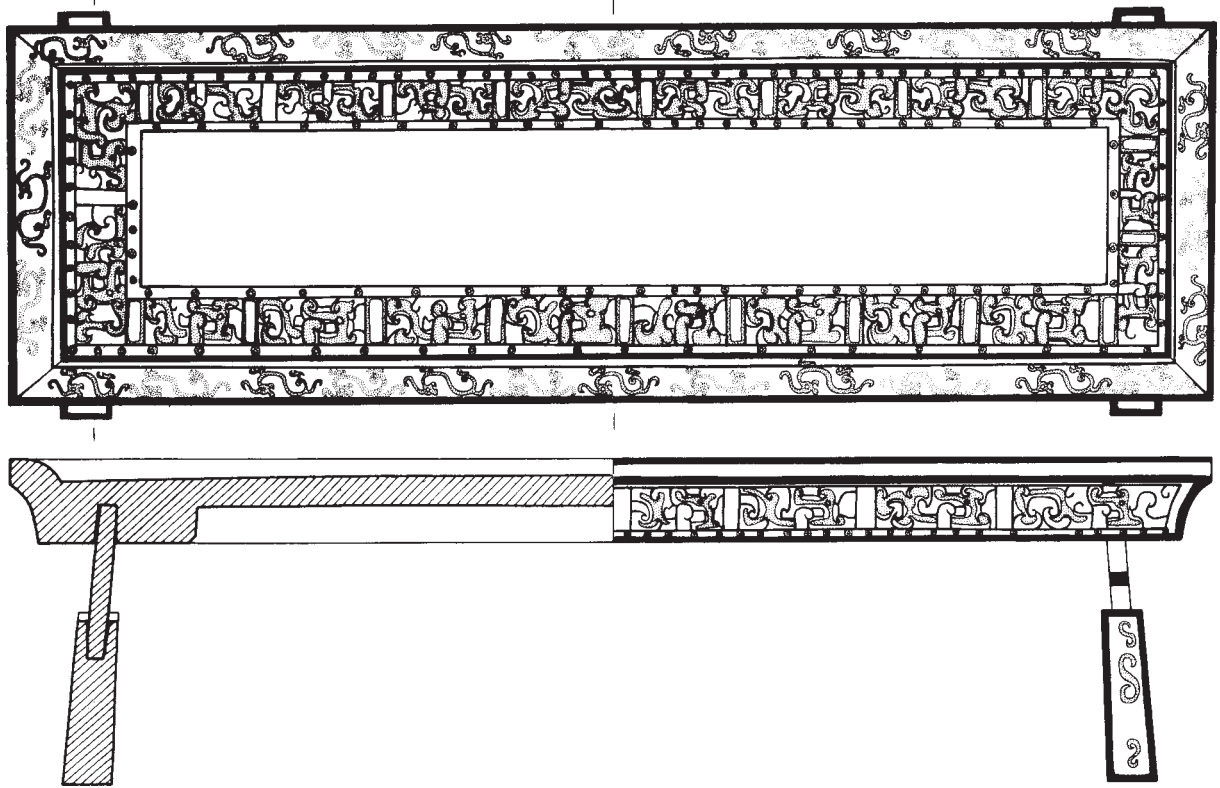

Fig. 16 Plan and elevation of type B lacquer ritual board
 Top (coffin No. 2:9) Left and right legs (coffin No. 2:13 and 16) (scale: 1/9)

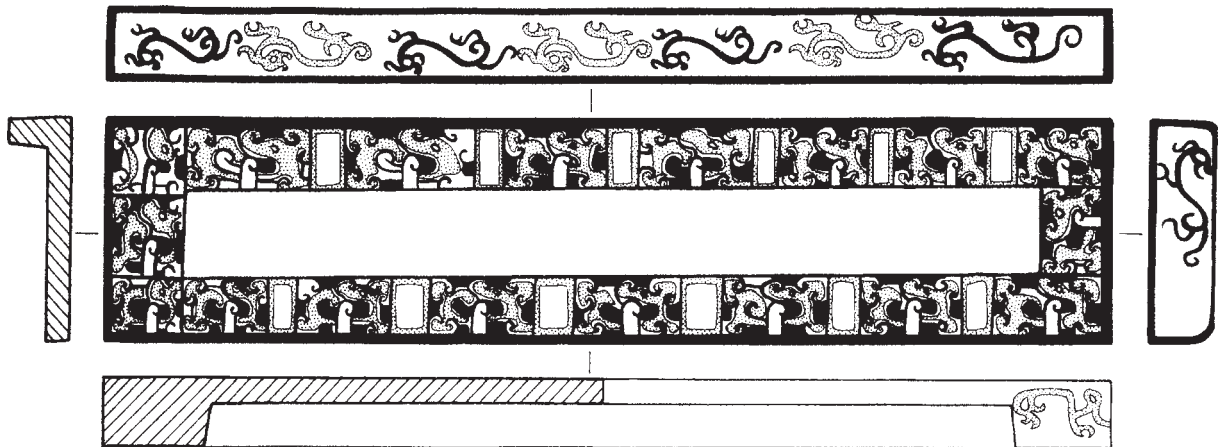

Fig. 17 Small lacquer table (coffin No. 2:45) (Scale: 4/27)

only occupy a large quantity and resemble fine craftsmanship, but also are well preserved. The lacquer objects are all wooden-bodied with red designs on black background painted in lacquer. The decorative patterns are mainly flying-dragon and transformed dragon patterns in groups. On some lacquer wares are lots of

carved signs, mainly found on the components of some vessels. Most of the lacquer wares are utensils while some are musical instruments. Apart from the lacquer wares, there are also many wooden wares, including combs and some wooden items unknown to us (Figs. 14–24).

Fig. 18 Small table-shaped lacquer ware (coffin No. 8:5)



Fig. 19 Lacquer top of ritual board (coffin No. 2:9)



Fig. 20 Lacquer top of ritual board (coffin No. 2:39)



Fig. 21 Lacquer plate (coffin No. 2:30)



Fig. 22 Lacquer box (coffin No. 2:28)



Fig. 23 Lacquer drum (coffin No. 1:37)



Fig. 24 Lacquer stand (coffin No. 1:40)

IV. Dating and Nature of the Tombs

1. Dating of the tomb. The unearthed pottery such as the lids, flat-bottomed *guan*-jars, round-bottomed *fu*-cauldrons, pointed-bottom *zhan*-cups and *dou*-pedestal bowls as well as the bronze are typical wares of Bashu 巴蜀 Culture reflecting characteristics of the early Warring States period. Yet some sort of Chu-ware style can be discerned from the shape, making technique and characteristics of the decorative patterns of the lacquer

ware. But the strong local color distinguishes them from those of Chu ware and indicates that these lacquer wares were produced in Chengdu. They ought to be produced earlier than the Chu ware of the middle and late Warring States period unearthed from the neighborhood of Jiangling 江陵, Hubei 湖北 Province. These lacquer wares bear similarity with those of the late Springs and Autumns period unearthed from Dangyang 当阳, Hubei. The dragon patterns on many lacquer wares are also very similar to those on the bronze ware inlaid with

copper of the early Warring States period unearthed from central China. These burial accessories retrieved from the boat-coffins and single-log coffins fundamentally demonstrate that the date of this tomb ought to fall within the late stage of early Warring States period, which happens to be the late period of Kaiming 开明 Dynasty: the last dynasty ruling the ancient Shu State.

2. The structure of the tomb. The tomb is massive in scale and peculiar in structure: the elaborate structure of ground structure on tomb pit. And the parallel arraying of many boat-coffins and single-log coffins on padding plates inside a large pit of about 20 or 30 m long and wide is first discovered in archaeological data in China. Though the ground structure can no longer be seen in full now, one can still perceive the grandeur and solemnity of it. This kind of ground structure is probably used for memorial ceremony, which is an inheritance and even further development of the old system of Shang Dynasty in the Warring States period. It ought to have something to do with the origin of the ancient

burial rituals of the royalty and indicates that the religious rituals of ancient Shu have also reached a high level. The large boat-coffins made of hollowed-out logs are fine in quality and exceed all boat-coffins discovered in the past. Besides, the large quantity and volume of those boat-coffins also rank them as the champion of their fellow products in China. The bright and colorful lacquer wares unearthed are especially fine works of Warring States lacquer ware, important objects for research of the technique involved in making lacquer ware in ancient Shu. Their discovery indicates that the making technique of lacquer ware in Shu was very advanced in as late as the early Warring States period, the products can even compare with those unearthed from Chu State of the same period. Generally speaking, the tomb shows how distinguished the occupant is in social rank: he must be a member of the upper ruling class in Kaiming Shu State. It is even likely that this tomb is the rare clan tomb of the royalty of Kaiming Dynasty or even the tomb of the ruler himself.

Note: The original report is published in *Wenwu* 文物 2002.11: 4–30, with 43 photos, written by Jiang Cheng 蒋成, Yan Jinsong 颜劲松, Chen Yunhong 陈云洪, and Liu Yumao 刘雨茂. The present version, an abridgment from the original, is prepared by the first two authors and English-translated by Wang Shufang 王淑芳.