

# Stone Coffin Tombs of No. 1 Boulder Mound at Locality 2 in Niuheliang Site of Hongshan Culture

Liaoning Provincial Institute of Cultural Relics and Archaeology

Key words: Niuheliang Site (Jianping County, Liaoning Province) Cairns-China Cist Graves-Hongshan Culture

The Niuheliang site group of Hongshan Culture has been affirmed to be a vestige complex consisting of above 20 localities with altars, a “ temple-site, ” stone-barrow cemeteries, etc. At the center of the site group is the second locality (NII), which includes five barrows and

an altar. Among them Barrow I (NIIZ1) is a stone building-unit distinct in shape, good in condition and great in the number of excavated burials and unearthed jades (Figure 1). So far, 25 stone-coffin tombs of various types have been revealed, and some of them have been pub-



Figure 1. Plan of Barrow I at the second locality

lished in advance. The present paper will make an account of eight previously unpublished tombs that are typical in layout, structure and burial manner. The following designations show their excavation years and numbers: 87NIIZ1M17, 87NIIZ1M19, 89NIIZ1M20, 89NIIZ1M22, 91NIIZ1M23, 91NIIZ1M24, 91NIIZ1M25 and 91NIIZ1M26 (below all called by their truncated numbers)

**Condition of Tombs**

M25 and M26 among the eight tombs are located on the west-to-east central axis of Barrow I, while the rest six tombs are arranged from west to east in the southern half of the barrow.

1. M17 is situated in the south of the barrow, a little to the east, adjacent to M19 and M20 on its southern and northern sides respectively. The tomb chamber is in a good condition and has an azimuth of 83°. The coffin

is covered with multiple layers of stone slabs, its walls are made of four standing dressed limestone slabs and supported by large stones from outside, and the bottom is earthen. The wall slabs are varied in height, ranging 0.24–0.39m, and are 0.03–0.05m thick. The whole coffin measures 0.51 × 0.25m and 0.59 × 0.25m for the opening and bottom respectively. The interior is filled with black silt, which contains only a human skull with the face upward and a palm bone. It is the remains of a male. On the right of the skull is a funeral jade ornament decorated with double human heads and three perforations (Figure 2).

2. M19 lies also in the south of the barrow, a little to the east, with M17 and M8 on the northern and southwestern sides respectively, measuring 78° in orientation. The stone coffin has been disturbed and the western wall missing. The tomb ceiling has collapsed and stone blocks were scattered down from above. The eastern wall is an erect stone slab, the northern and southern ones are built of upright irregular stone blocks and slabs, and all walls are supported with large-sized stones from outside. The whole coffin measures 0.99m in remaining length, 0.58m

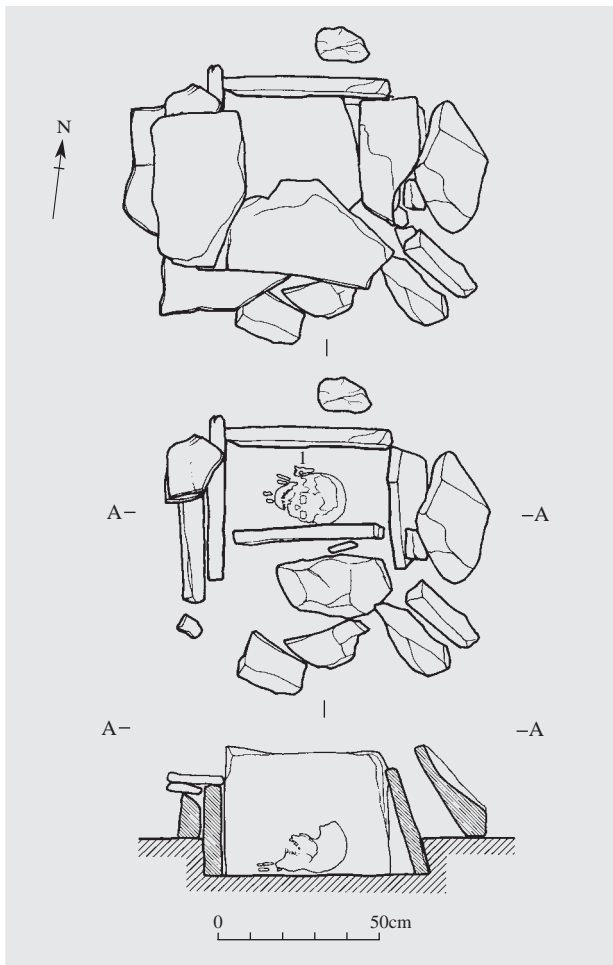

Figure 2. Plan and section of Tomb M17  
1. jade ornament with double human head designs and three perforations

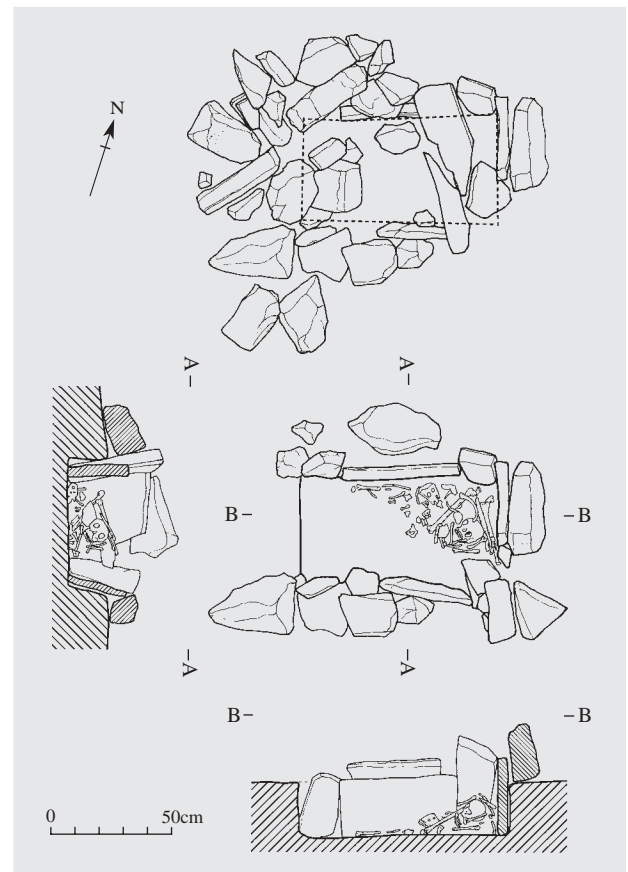

Figure 3. Plan and section of Tomb M19

in width and 0.3–0.45m in height. Its interior is filled with mixed black earth, which contains a few red clay potshards. This is a secondary burial with human bones heaped up randomly in the east and without grave goods (Figure 3).

3. M20 is in the center of Excavation Square T0604, beneath the inner southern wall in the south of the barrow, and adjacent to M27 on the eastern side and to M15 on the southwestern side, and has an orientation of 252°. The four coffin-walls are built of dressed single or multiple limestone slabs, which are well erected except for the inward-inclined northern wall. The top is made of pieced-together stone slabs in several layers, and the bottom is an earthen floor. The coffin is 1.92m long, 0.24–0.28m wide and 0.18–0.20m high. It contains a single human skeleton lying in an extended supine position, heading east. No grave goods were found (Figure 4).

4. M22 is in the south of the barrow, a little to the west, and adjacent to M23 and M24 on the western side, forming a straight west-to-east row with them. Intruded by a modern gully, its boundary has become unclear; only a few remaining stones and a human skeleton on the bottom represent its existence. The bottom is cut in the weathered surface of the bedrock at a depth of 1.3m beneath the present-day ground. The skeleton

lies in an extended supine position, heading east with an azimuth of 75°. The skull has been disturbed, and the pelvis and left leg bone are missing. Among the unearthed grave goods are a sleeve-shaped object, an animal-mask-shaped pendant and a bracelet, all in jade (Figure 5).

5. M23 is in the southwest of the barrow, on the bottom of the modern gully, within Excavation Squares T0204 and T0304. Owing to damage by the gully, the grave is gone on the whole. The stone coffin had only some broken stones of the northern wall reserved, which show the wall to have been laid by rather regular limestone blocks. It is 0.26m in remaining height. The western wall is built from the bedrock and has been intruded by M24; the remaining length measures about 2.4m, and the depth is about 1.9m beneath the ground. The remains suggest that the tomb must have been a deep rectangular earthen pit furnished with a stone coffin. It contains a single burial in an extended supine position, the remaining skull and four limb bones showing an azimuth of 82°. Four pieces of grave goods are unearthed, in-

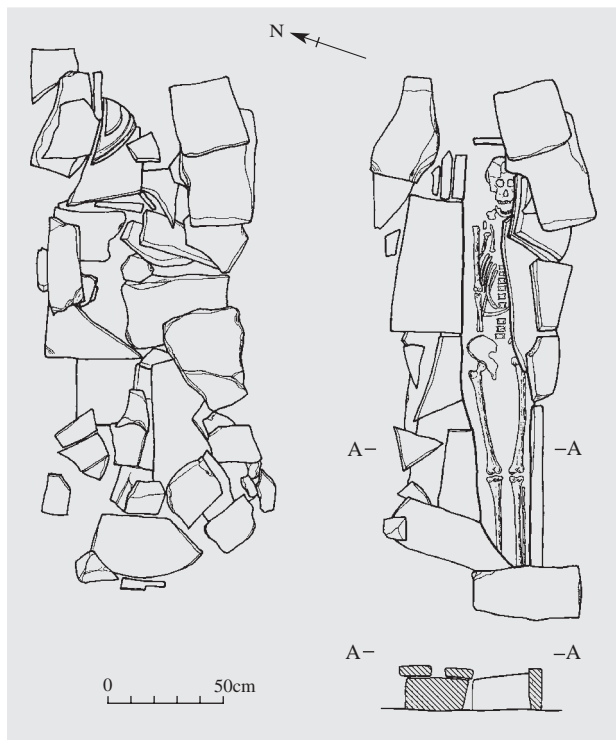

Figure 4. Plan and section of Tomb M20

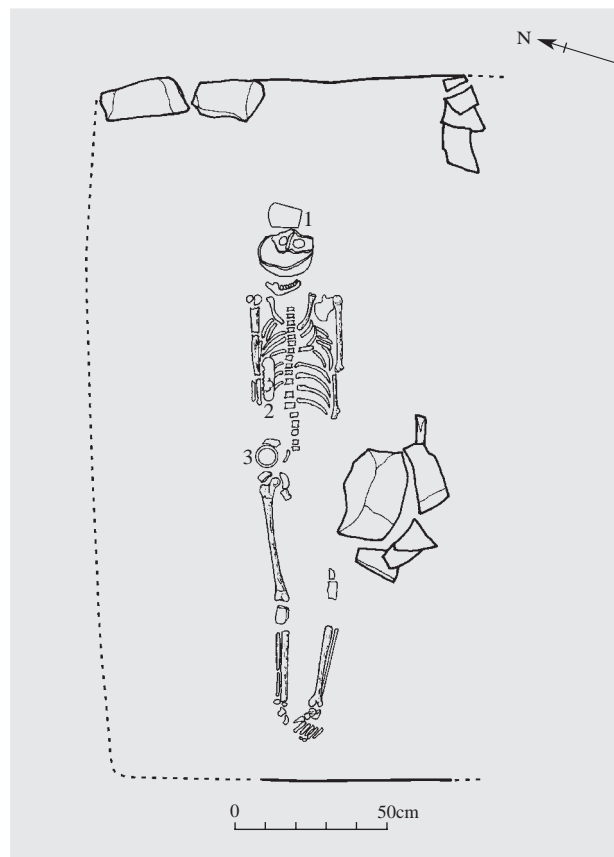

Figure 5. Plan of Tomb M22

1. Sleeve-shaped jade object 2. Animal-mask-shaped jade pendant 3. Jade bracelet

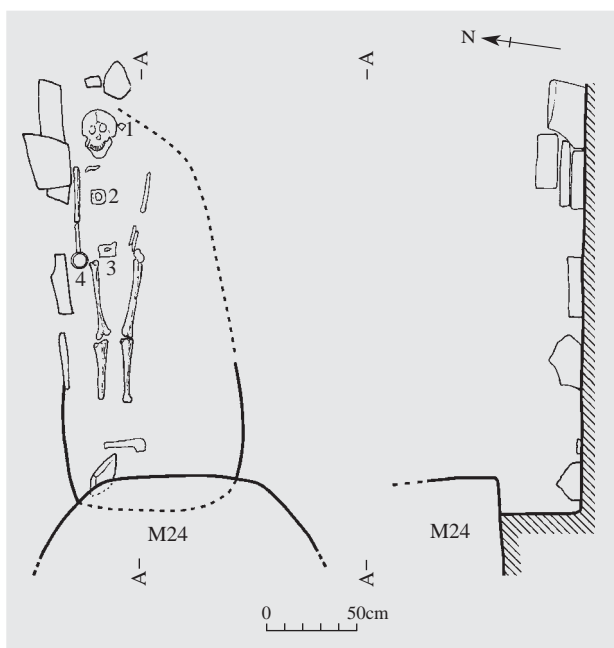

Figure 6. Plan and Section of Tomb M23

1. Turquoise pendant 2. Jade yue-battle axe 3. Jade pendant with bird and animal design 4. Jade bracelet

cluding a turquoise pendant, a jade *yue*-battle axe, a jade pendant carved with bird and animal design, and a jade bracelet (Figures 6 & 7).

6. M24 is at the western end of the south of the barrow, in Excavation Squares T0104 and T0204, intruded M23, and is 84 ° in orientation. Owing to erosion by the gully, its southern boundary has become unclear. The earthen pit has a sub-rectangular plan, opening smaller than bottom, and measures about 3.3m in length, about 1.95m in width and 2.22m in depth. It is cut in the weathered bedrock. On the bottom is a double-chamber stone coffin good in condition. Its building way is as follows: The eastern wall is made of an erecting large stone slab; the southern, northern and western walls are built of 10–12 courses of thin stone slabs laid on flat, and the formed large frame is divided into two roughly equal chambers with a partition built of small-sized slabs laid on flat. The stone coffin is 1.9m long and 0.4–0.52m high. Its roof is made of two layers of stone slabs on flat, and the bottom is cut in the weathered bedrock. The northern chamber, 0.4m wide, contains an adult female skeleton lying in an extended supine position; the skull has been broken; and the grave goods consist of two jades: a bracelet and a hooked-cloud-shaped pendant. The southern chamber measures 0.35m in width, contains the remains of a male in good condition, identical with the former in



Figure 7. A full view of Tomb M23

burial manner, and buried with a jade bracelet (Figures 8 & 9).

7. M25 is situated in the east of the west-to-east central axis of the barrow, covering the adjacent corners of Excavation Squares T0605, T0705, T0606 and T0706. In shape it represents a newly discovered type. The pit opening is wide and has a rectangular plan, the eastern, western and northern walls are gradually inclined inward from the bottom to the opening, and the bottom is deep-cut in the weathered bedrock. On the southern side of the pit is a stepped passage consisting of six steps unequal in height, all extending fully between the western and eastern walls. The stone coffin is structured on the bottom, against the northern wall. It is rectangular in plan, with the middle wider than the ends, and has an azimuth of 257 °. Its walls are built of 8–12 courses of



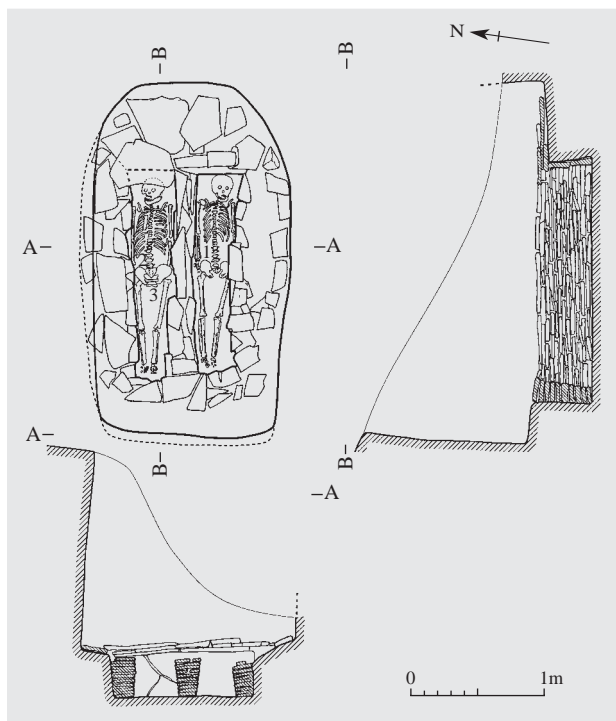

Figure 8. Plan and section of Tomb 24  
1 and 2. Jade bracelets 3. Hooked-cloud-shaped jade pendant

silico-limestone slabs laid on flat and in staggered-joint bond. The stone slabs are unequal in thickness and are largely dressed, the crevices between slabs are very narrow, and the inner wall-surface is made rather even. The stone covering is missing, and the bottom is paved with large stone slabs. The northern half of tomb-pit opening has been destroyed by the gully, while the lower part and the coffin are well preserved. The whole pit is about 3.5m long from north to south, about 3.15m wide from west to east, and 2.7m deep in the maximum depth. The steps are 0.2–0.45m high each and 0.35–0.45m wide. The coffin measures 1.96m in length, 0.48m in width and 0.54–0.66m in height. It is filled with a mixture of yellow earth and granulated sandy bedrock, and contains an adult female skeleton in an extended supine position, head pointing to the west. The grave goods consist of seven jades: two beads, two sleeve-shaped objects, two bracelets and a tubular ornament with an oblique mouth (Figures 10 & 11).

8. M26 lies in the west of the central axis of the barrow, in Excavation Square T0305, and has an azimuth of 255°. It corresponds to M25 located in the east, has the same shape and structure as the latter and is well preserved. The tomb pit is rectangular in plan with the



Figure 9. A full view of Tomb M24

upper part wider than the bottom. The opening measures 3.95m in length, 3.42m in width and 1.95m in the maximum depth for the northern side. The southern side is furnished with a five-step passage, each step measuring 0.3–0.7 in width and 0.2–0.35m in height. The stone coffin is on the northern side, no covering remains, the walls are built of six courses of regular stone slabs and blocks laid on flat and in staggered-joint bond, with the inner surface made even and straight. The opening is surrounded with a circle of undressed irregular stones, and the bottom is also paved with stone slabs. The whole coffin is 1.94m long, 0.45m wide and 0.45m high. The pit is filled with yellowish earth mixed with small amount of granulated bedrock, which is rammed hard and compact. The coffin is filled with soft earth and contains a disordered human skeleton lying in an extended supine position. The grave goods number four: a double-owl-shaped pendant, an oblique-mouthed tubular ornament, a bracelet and a plaque, all in jade (Figures 12–14).

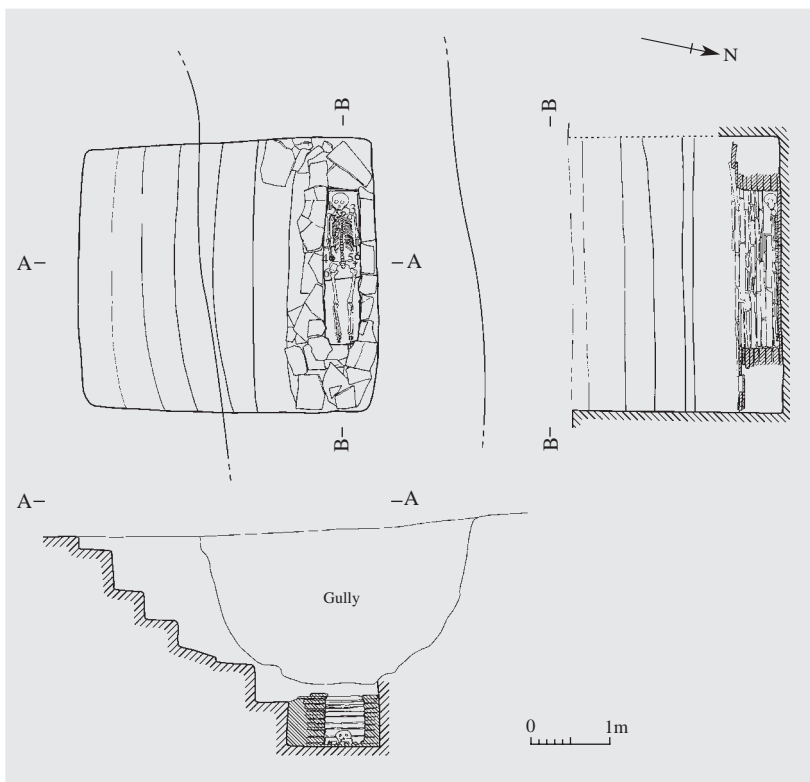

Figure 10. Plan and section of Tomb M25

1 and 2. Jade beads 3 and 6. Sleeve-shaped jade objects 4 and 5. Jade bracelets 7. Oblique-mouthed tubular jade ornament



Figure 11. Stone coffin in Tomb M25

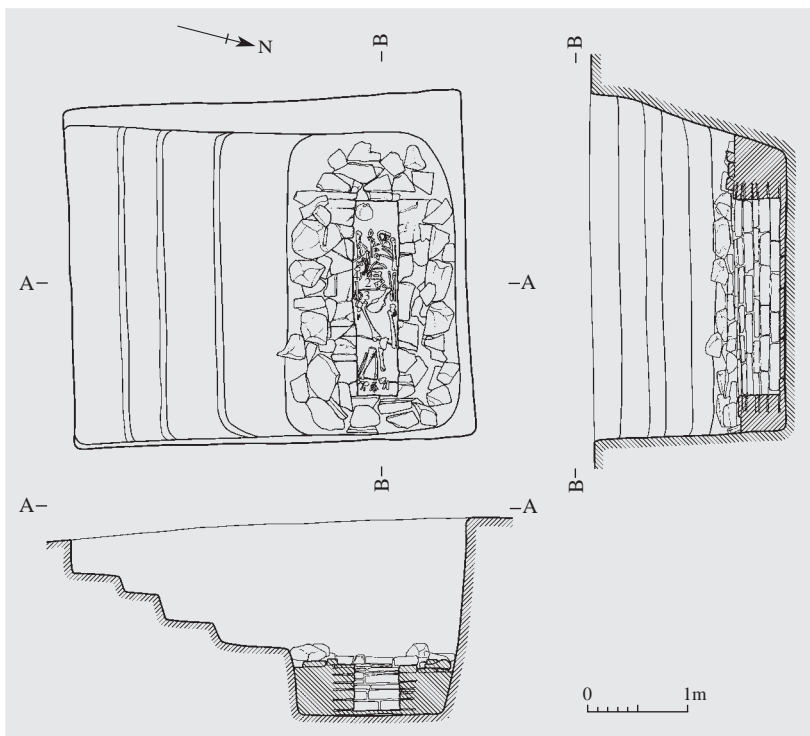

Figure 12. Plan and section of Tomb M26

1. Oblique-mouthed tubular jade ornament 2. Double-owls-shaped jade pendant 3. Jade bracelet 4. Jade plaque



Figure 13. Stone coffin in Tomb M26





Figure 14. A full view of Tomb M26

### Grave Goods

Of the eight tombs, M19 and M20 contain no grave goods, whereas the other six tombs yielded 22 objects in total, i.e. 21 jades and a turquoise ornament.

Jade bracelets, seven pieces. They have a circular plan, inner edge thicker than outer one, section usually looking like a curved-side triangle, body plain, bright and smooth-polished, and size a little varying. M24:1 is yielded from the southern chamber of the coffin. It is light green and bears in the middle of the inner edge a raised line, which must have been resulted from cutting the core off by bifacial drilling. The diameter is 7.2cm for the outer edge and the thickness 0.5cm (Figure 15). M24:2 is unearthed from the northern chamber of the coffin. It is identical with M24:1 in color and shape. In the body is a bifacial perforation. Its diameter is 7.7cm for the outer edge, and the thickness is 0.6cm (Figure 16).

Jade beads, two pieces. They are greenish-yellow and look like a fish spine. The middle is contracted, the ends are thinned, and the body has a bifacial perforation. M25:1

measures 1.3cm in height and 1.2–1.5cm in diameter.

Jade plaque, one piece (M26:4). It is slightly flat and sub-triangular with the obverse smooth while the reverse uneven. The edge is irregular and bears a bifacial perforation. The length is 6.7cm and the width 5.8cm.

Sleeve-shaped objects, three pieces. They look like an oval-sectioned cylinder with an end oblique and the other level, which has two small perforations. The body is polished and plain, and the level end has two small perforations near the edge. M22:1 is dark green and measures 9.1cm in length, 8.5cm in the maximum width of the oblique end, and 7.0 and 5.5cm in major axis and minor axis respectively for the level end (Figure 17). M25:3 is light green. The inner wall bears traces of bifacial perforation and thread cutting. The length is 13.6cm and the maximum width 8.3cm at the oblique end. M25:6 is dark green, bears traces of thread cutting on the inner wall, and measures 11.1cm in length, 8.7cm in maximum width for the oblique end (Figure 18).

Oblique-mouthed tubular object, two pieces. Either is an oval-sectioned cylinder with the two ends oblique

and different in length. The middle is slightly contracted, and the surface is plain. M25:7 is yellowish-green, and measures 4.6cm in length, 3.0 and 2.6cm in major axis for the thicker and thinner ends respectively, and 0.6cm in the maximum thickness of the wall.

Jade *yue*-battle axe, one piece (M23:2). It is light green; the surface is largely whitish owing to calcification. The body is flat and looks like a horizontal rectangle with an even top, a curved edge, and a bifacial perforation 3cm in diameter in the center. Near the

top are two small perforations and, between them, a groove resulting from tying. The length is 12.4cm and the maximum width 10.5cm (Figure 19).

Hooked-cloud-shaped jade pendant, one piece (M24:3). It is light green and flat-bodied with openwork design. At the corners are symmetrical out-turned hooks, and in the center is an openwork curve. The obverse is carved with a veiled cirrus-shaped groove in intaglio. At the upper edge are two bifacial perforations in the middle, and a groove for tying is cut between them. This object



Figure 15. Jade bracelet (M24:1)



Figure 16. Jade bracelet (M24:2)



Figure 17. Sleeve-shaped jade object (M22:1)

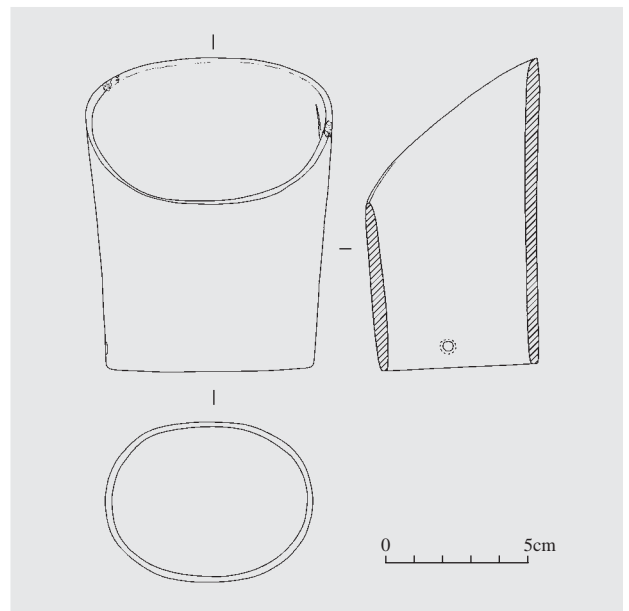

Figure 18. Sleeve-shaped jade objects (M25: 6)



had been broken into three fragments and restored by tying through six small bifacial perforations in three groups. The reverse is plain. The length is 17.9cm, and the width 10.9cm (Figures 20 & 21).

Animal-mask-shaped jade pendant, one piece (M22:2). It is yellowish-green with white spots. The body is flat, narrow and long, has a small bifacial perforation in the middle of the upper side, and is rounded at the corners. The obverse is different from the reverse, but either is shaped like an animal mask. The obverse is carved with a regular design showing the brows, eyes and teeth of the animal with the technique of openwork and veiled groove engraving. The length is 14.3cm and the width 4.7cm (Figures 22 & 23).

Jade ornament with two human head designs and three perforations, one piece (M17:1). It is white and bears the same design on the two faces. The ends are carved

with two human heads, between which are three wide-opened equal-sized holes, and on the lower side are three bifacial perforations. Between the two rows of holes are a raised wide stripe and a row of short oblique lines in intaglio. The upper edge is shaped into triple curves in accordance with the large holes, while the lower edge is level. The human heads are high fore-headed, in a high crown, round-orbited, round-nosed and elongated chinned, lips slightly opened. The whole object measures 6.8cm in length and 3.1cm in maximum width (Figures 24 & 25).

Double-owls-shaped jade pendant, one piece (M26:2). It is transversely laid on the tomb-owner's belly with the obverse upward. The material is greenish-yellow, the body is flat, and the ends are symmetrically carved with two identical owl-heads, the feathers like ears rounded and erected, the cheeks plump and smooth, the



Figure 19. Jade yue-battle axe (M23:2)



Figure 21. Hooked-cloud-shaped jade pendant (M24:3)

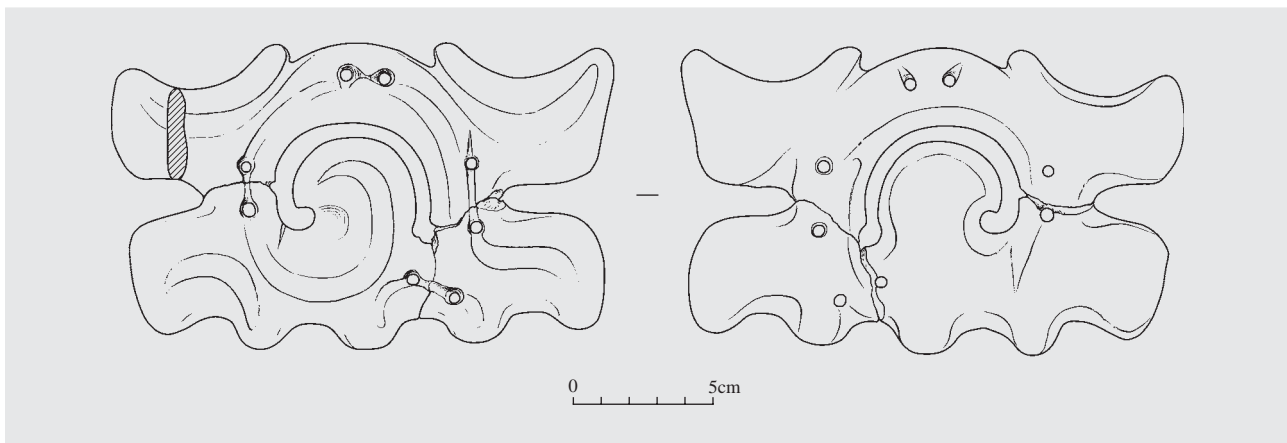

Figure 20. Hooked-cloud-shaped jade pendant (M24:3)

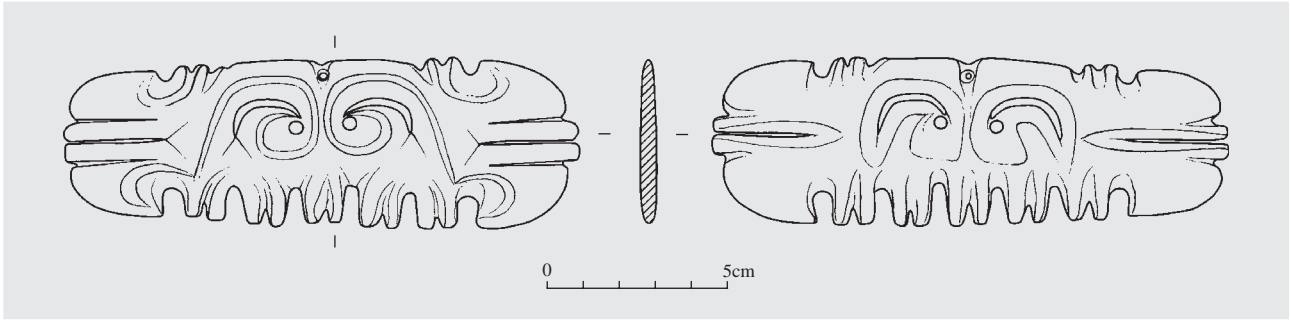

Figure 22. Animal-mask-shaped jade pendant (M22:2)

wide-opened eyes depicted with thinner and thicker lines in intaglio, and the beak presented by emphasizing the hook. The center is made into an oval hole, either side is carved with six veiled grooves, and the outer edges are shaped like flanges to present the wings. The reverse has no design and bears clear traces of cutting. In the body are diagonal perforations arranged in triangle plan. The length is 12.9cm and the width 9.5cm (Figure 26).

Bird and animal design jade pendant, one piece (M23:3). It is yellowish-green with a few yellow spots occurring on the calcified surface. The body is flat with the center a little thicker than the edges and is engraved with a design in intaglio depicting a bird and an animal in combination. In the center is a pear-shaped hole. The animal head has projecting lips, a long tongue and round eyes, and the body is curling. The bird wears a high crown and has round eyes and an upward protruded beak. The reverse is a little concave and bears traces of emery wheel working and four groups of oblique bifacial perforations for wearing. The length is 10.3cm and the width 7.8cm (Figure 27).

Turquoise pendant, one piece (M23:1). The obverse shows the texture of turquoise, and the reverse keeps the black surface of the raw material. The body is shaped like a trapezoid slice with a small bifacial perforation at the upper end. It is 5.2cm long and 1.5–3.9cm wide.

### Summary

The stone barrows at various localities of Hongshan Culture at Niuheliang varied in shape and arrangement, structure and burial manner of the interior tombs, and also in the type and number of their grave goods. Below is an analysis and



Figure 23. Animal-mask-shaped jade pendant (M22:2)

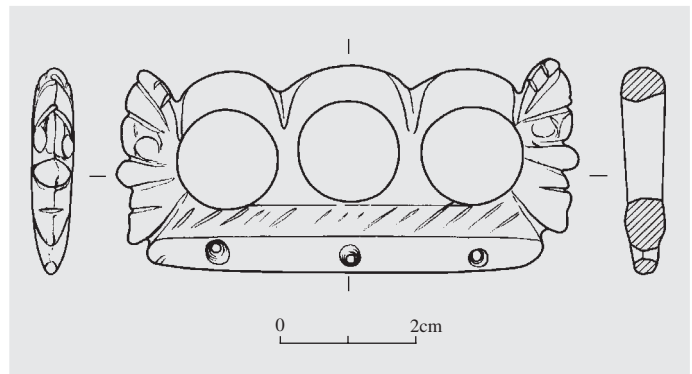

Figure 24. Jade ornament with double human head designs and three perforations (M17:1) (life-size)



Figure 25. Jade ornament with double human head designs and three perforations (M17:1)



Figure 26. Double-owls-shaped jade pendant (M26:2)



Figure 27. Jade pendant with bird and animal design (M23:3)

summary of the unearthed data from Barrow I.

1. Barrow I is a large-sized stone building consisting of an aboveground part and an underground one. The former is built of large silico-limestone blocks, and the latter is mainly tombs arranged densely and tidily. The northern and eastern walls of the barrow are fairly good in condition, the western wall has been destroyed by a gully, and the southern one is unknown. The whole barrow measures 26.8m in remaining length from west to east, and 19.5m in maximum width from north to south. The northern wall is combined of four rows of stones, of which the outer two are single-line single-course straight and regular structures with a level top, which form the first terrace. Inside the two structures is a row

of painted pottery cylinders, of which over 60 pieces are discernible in type, but mostly have become fragments or powder-like remains except for the bottom shards remaining *in situ*. The two inner rows left over stone blocks in intermitting lines; the traces of their original superstructure show them to have been the foundations of the second terrace on the northern side of the barrow. The eastern wall is higher in the north and lower in the south according to the natural terrain, and measures 16.2m in remaining length. The northern end is a single-course structure, while the southern end reaches four courses of staggered-joint bond, measuring 0.9m in remaining height. The wall top is roughly level. This wall consists of three rows of stones. The tops of the outer two rows are at the same level and form the first terrace, on which fragments of cylindrical objects were found in a large number. The third row is parallel to the two outer rows and higher than them. It is built of smaller stones laid on flat and in staggered-joint bond. To prevent from collapsing, it is intentionally battered. Its remains are about 0.8m higher than the first terrace. At the southern end is an L-shaped corner with the westward-extending wall dividing the barrow into two parts: the north and the south. In the former, among numerous huge stone blocks, M25 and M26 were found to be large-sized earthen-pit tombs arranged symmetrically in the east and west respectively, both furnished with a stepped passage and a stone coffin. The south is filled with mixed earth in yellow color, under which stone-coffin tombs largely in medium and small size are densely arranged with the central axis pointing to the west and east, some double-burial groups sharing the same wall and some being superimposed on or intruded by others. The excavated graves number 25.

2. Tomb shape. All of the tombs in Barrow I are furnished with stone coffins. Nevertheless, they differ in shape and structure and fall into four types.

1) The large-sized earthen pit with a stepped passage and a stone coffin. The tomb pit is spacious and roughly square in plan for the opening, and has a bottom cut in the weathered bedrock. On the southern side is a stepped passage leading down to the bottom, while on the northern side, a large stone coffin is built of dressed stones laid on flat. The unearthed rich funeral jades show the high rank of the burial. M25 and M26 can be taken as representatives of this type.

2) The deep earthen pit with a stone coffin. The pit is rectangular, bottom cut in the weathered bedrock. The



coffin is built of stones laid on flat and structured in staggered-joint bond. The grave goods are rich. This type of tomb is represented by M21.

3) The earthen pit with a double-chamber stone coffin. The pit is wide and deep. On the bottom is a stone coffin partitioned into two chambers, either of which contain a human skeleton. The grave goods are small in quantity. This type is represented only by M24 among the Hongshan Culture tombs at Niuheliang.

4) The simple stone-coffin tomb. This type of tomb has no definite pit or only a shallow pit with the opening on the same level as that of the stone coffin. The coffin is small and narrow and usually has a stone cover. Its walls are largely made of erect stone slabs as seen in M4, M17, M20 and M16, or built of those combined with stones laid on flat and in staggered-joint bond as recorded in M7, M11 and M15. No or few grave goods were yielded. This type of tomb accounts for the most and must have belonged to a later time among the burials of Barrow I.

3. Burial manner. The numbered tombs in Barrow I total 27, of which the excavated are 25. There are four vacant or seriously disturbed tombs with human skeletons missing, and the rest of 23 tombs include a few two- or three-person burials. Altogether the unearthed human bones belong to 27 individuals; their burial manner falls mainly into two types: primary burial and secondary burial.

Primary burial is the most common burial manner in the Hongshan Culture. It is largely practiced as single burial except for the only joint burial in M24 that contains in the double chambers of the same pit two adult human skeletons different in sex and grave goods. The skeletons of primary burial are mostly in an extended supine position as discovered in 13 examples, accounting for nearly a half of the total. Flexed supine burial occurs only in one case, namely in M4.

The secondary burials account also for a considerable proportion and fall into single- and multiple-person sub-types. The latter can be exemplified by M7, which has a pit “凸”-shaped in plan and contains three heaps of human bones belonging to three individuals, and five jades of the bracelet and *bi* disc types were yielded in association with these bone heaps.

Postscript: The original is written by Zhu Da 朱达 and published in *Wenwu* 文物 (Cultural Relics) 2008. 10: 15–33 with 36 illustrations in the text and one photograph on the cover. The present version is prepared by the author and translated into English by Mo Runxian 莫润先.

4. The tombs in Barrow Niuheliang-I yielded no funeral pottery and stone implements but jades and a turquoise ornament. On the other hand, they share the same painted pottery cylinders placed on the barrow, which became a sharp contrast to the entombment of funeral jades representing personal properties.

Jade objects were unearthed from the barrow more than 70. Of them almost 50% belong to the bracelet and *bi*, two types of pendants also commonly seen in other Neolithic cultures. The jade objects characteristic of the Hongshan Culture are bird and animal design ornaments combined in sets. They feature large size and distinctive technology, as exemplified by sculptured pig-dragons and tortoises, as well as animal-mask plaques with designs contoured in intaglio and presented in veiled grooves. Especially noteworthy are the double-owls-shaped pendant and the bird and animal design pendant. Both are plane jade slices carved with deep-implying designs by intaglio line and contour wheel-engraving, as well as by openwork, ground-reducing (relieving) and concave curve and veiled groove incising, which produce distinct gradation, three-dimensional impressions and dynamic effects. By seeking likeness in spirit and exact symmetry, prehistoric artisans made peculiar aesthetic generalization of animal appearances and created new deities according to the imaginary figures of the worshipped objects that were deified in primitive life. Their imaginative ability and jade-carving skills reached the apex of jade working in prehistoric times. We believe that the bird and animal design pendant from M23 must have been a work integrating dragon and phoenix figures into a whole.

## References

- Liaoningsheng Wenwu Kaogu Yanjiusuo 辽宁省文物考古研究所 (Liaoning Provincial Institute of Cultural Relics and Archaeology). 1986. *Liaoning Niuheliang Hongshan Wenhua “Nü Shen Miao” yu Jishi Zhong Qun Fajue Jianbao* 辽宁牛河梁红山文化“女神庙”与积石冢群发掘简报 (Excavation of a “Goddess Temple” and Stone Barrows of the Hongshan Culture at Niuheliang, Liaoning). *Wenwu* 文物 (Cultural Relics) 8: 1–17.
- Zhu, Da 朱达. 1997. *Liaoning Niuheliang Di er Didian Yihao Zhong 21 hao Mu Fajue Jianbao* 辽宁牛河梁第二地点一号冢 21 号墓发掘简报 (Tomb 21 of Mound 1 of Locality 2 at Niuheliang in Liaoning). *Wenwu* 8: 9–14.