

# Tomb of Kang Ye of the Northern Zhou in Xi'an, Shaanxi

Xi'an Municipal Institute of Archaeology and Preservation of Cultural Relics

*Key words: Tombs-Northern Zhou Dynasty-Xi'an City (Shaanxi Province) Art, Sogdian-China Tomb of Kang Ye*

In April of 2004 our Institute excavated a tomb from the Northern Zhou Dynasty in the northern suburb of Xi'an. The tomb occupant's name is Ye, a citizen from the State of Kang in the territory of Sogdiana. The archaeological materials excavated from this tomb provide invaluable evidence for the study of the cultural exchange between East and West and the art of painting in ancient China.

Kang Ye's tomb is located southeast of the intersection between Weiyang Grand Boulevard and North Second Ring Road in the northern suburb of Xi'an municipality. It is northwest of the village Kangdizai, approximately 3500m east of the Northern Zhou capital Chang'an, approximately 150m north of the Northern Zhou tomb of An Jia, and approximately 2000m west of the Northern Zhou tomb of Shi Jun.

## Layout of Tomb and Excavated Objects

1. Kang Ye's tomb is an earthen dugout cave tomb with a tomb ramp and a burial chamber with domed ceiling. It is oriented to south at 179 degrees, and it consists of three parts: tomb ramp, tunnel passage, and burial chamber. The tomb ramp is located on the south side of the burial chamber; in the form of a slope, it has already collapsed and its length can no longer be determined. It is 1.58m wide, and the bottom is 7.90m deep below the ground at that time. The tunnel passage is an earthen dugout cave with vaulted ceiling, and the floor plan is roughly trapezoid, with the north end wider than the south end. It runs a length of 2.16 m; the south end is 1.42m wide, the north end is 1.5m wide. The ceiling has collapsed and the height can no longer be determined. The burial chamber is an earthen dugout cave with a domed ceiling, and the floor plan is almost square in shape. The sides are 3.3–3.4m in length, and the remaining wall is 1.6m high. As the ceiling has collapsed, the

elevation can no longer be determined. The tomb walls are decorated with murals that are now in poor condition. Adjacent to the north wall of the burial chamber is a stone couch enclosed by a screen along the sides and back. A tomb epitaph is installed at the south end of the burial chamber, and animal bones are found to the west of the tomb epitaph. In the middle of the burial chamber is a piece of burned ground approximately one sqm in size (Figures 1 & 2).

2. Sealing door. There are two doors. The first one is located outside the opening of the tunnel passage. It is

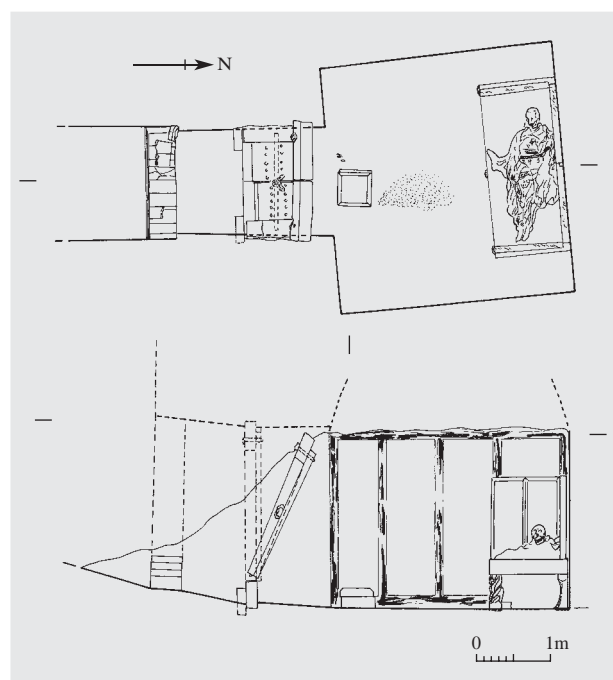

Figure 1. The Plan and Longitudinal Cutaway Section of M1 (Kang Ye's Tomb)

1. Gold Coin
2. Bronze Belt Buckle
3. Bronze Circles
4. Bronze Belt Plaques
5. Epitaph
6. Bronze Coin



*Figure 2. Bird's View of M1 (S-N)*



*Figure 3. The Stone Couch with Enclosing Screen*

sealed by a brick sealing wall, and in its ruinous condition it measures 0.30m in height. The second door is located inside the tunnel passage. Fashioned out of stone, it comprises the door lintel, door leaves, door frame, door threshold and door spacers that are fitted together with mortise and tenon joints. An iron ring is attached to either end of the door lintel, and the hinges of the stone doors are fitted inside the iron rings. The door lintel and door frame are engraved with linear designs. The front side of each door leaf is not engraved but has three rows of nail-heads (five in each row). The nail-heads are gold-plated. Attached in the middle of each door leaf is an iron door knocker with a horizontal wooden bolt placed through the rings.

3. Burial furniture. A stone couch with enclosing screen is located against the middle of the north wall of the burial chamber. It consists of the enclosing screen, couch platform and couch legs. The enclosing screen along the back and two sides is fashioned out of four rectangular stone panels: two back panels and the left and right panels. Both left and right panels are 93.5cm long, 82cm high, 7–8.5cm thick. Both back panels are 106–111cm long, 82–83.5cm high, 9–10cm thick. The inward-facing sides of the panels are polished and decorated with ten line engraved pictures; the left and right panels have two pictures each, and the back panels have six pictures. The pictures are partly gilded, and the two sides and top are decorated with gilded quartrefoil motifs. The couch platform is rectangular in shape, 2.38m long, 1.07m wide, 0.16m thick. The front and sides are carved with low relief designs. There are five couch legs, the three in front are shaped like crouching lions, and the two in the back are shaped like boots, and they are all 0.34m in height (Figure 3).

4. Style of burial. On top of the stone couch with enclosing screen is a human skeleton, the head oriented towards the west, the legs ori-



ented towards the east, the body lying supine with the limbs stretched out straight. The mouth holds a gold coin of the Roman Empire, and the right hand clutches a bronze coin. The tomb occupant dons a brocade robe, and the remains of the silk fabric of the robe are still clearly legible. The fabric is embroidered with coin patterns, diamond patterns, etc. A belt is tied at the waist, but only its bronze plaques remain intact.

5. Excavated objects. A tomb epitaph, nine bronze ornaments (one belt buckle, four pieces of belt latch, four circles for the pinholes), one gold coin from the

Eastern Roman Empire (held inside the mouth), one *buquan* bronze coin (held in the hand) have been excavated from the burial chamber.

There is one tomb epitaph, and the script style of the inscription is Wei Tablet. With a total of 397 characters, the inscription describes in detail the tomb occupant's family background and other circumstances (Figure 4).

There is one *buquan* bronze coin, round in shape with a square hole in the center, and inscribed in seal script with two characters “布泉 *buquan*”.

There is a single bronze belt buckle (M1:2). It is

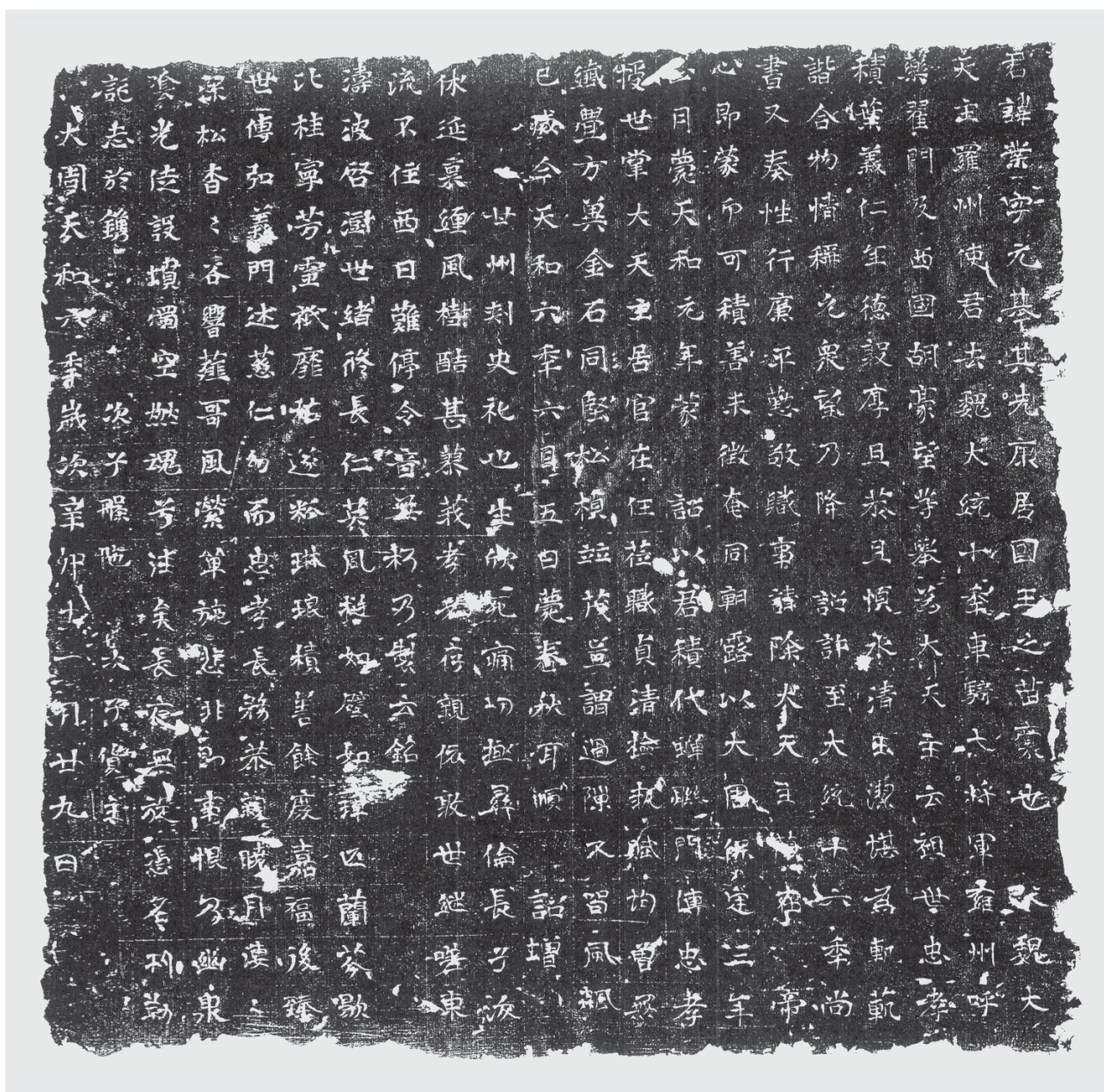

Figure 4. Rubbing of Kang Ye's Epitaph (M1:5)

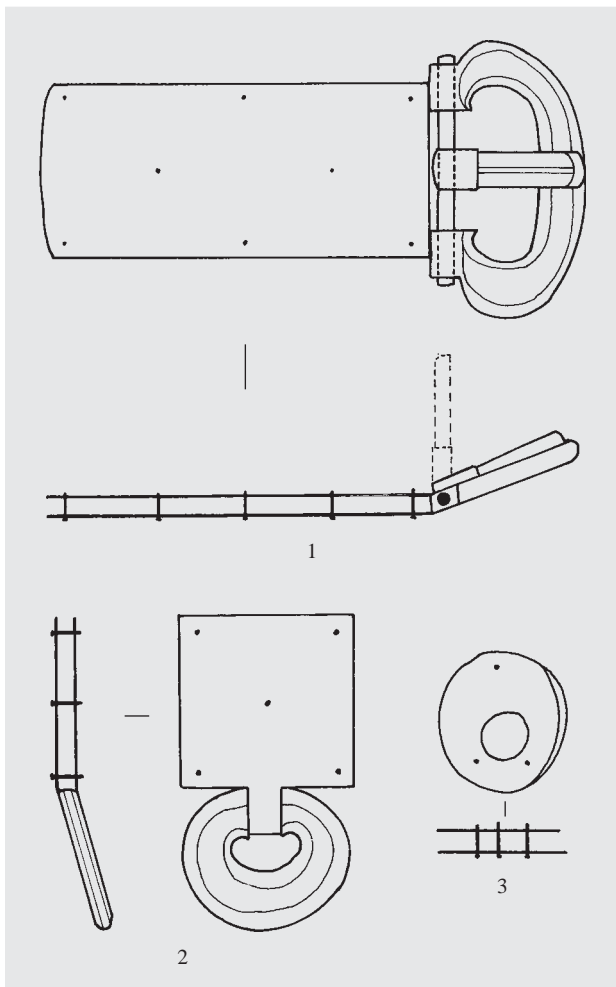

Figure 5. Bronzes  
 1. Belt Buckle (M1:2) 2. Belt Plaque (M1:4-1) 3. Bronze Circle for Pinhole (M1:3-1)

shaped like an oval with one straight side. It is 8cm long (Figure 5:1).

There are four pieces of bronze belt plaques that are identical in shape. The plaque comprises a squarish plate made of double layers of bronze sheets with five evenly spaced pin-shaped rivets and an oval-shaped ring fastened to the lower edge. Their overall length is 2.5cm (Figure 5:2).

There are four pieces of bronze circles for the pinholes. They are identical in shape, comprising double layers of bronze sheets that are shaped like oval circles with a round pinhole at one end. Their overall diameter is 1.8cm (Figure 5:3).

There is a single gold coin, round in shape, and the rim of the coin was worn out. On the front side is a bust portrait of the emperor donning an imperial crown with a row of linked pearl ornament. He is grasping the scepter in his right hand and resting it on the shoulder. The inscription along the rim of the coin reads DNIVSTINI/ANVSPPAV. On the reverse an angel is standing in the middle, with two wings emerging from the shoulders. His right hand is holding the cross, his left hand is holding a globe with a cross on top. The inscription along the rim is VICTORI/AAVGGGZ, and CONOB below. It is 1.81cm in diameter, 0.11cm thick, and weighs 2.1 grams (Figure 6).

### Wall Paintings and Line Engravings

#### 1. Wall Paintings

Murals are found in the tunnel passage and in the burial chamber. The mural technique involves first cov-



Figure 6. Gold Coin (M1:1)





ering the tomb wall with a layer of white plaster, then painting directly on this layer of white plaster. Because the entire burial chamber was infiltrated by silts, most of the white plaster and wall paintings have peeled off, and only the lines framing each pictorial unit are still legible. Each wall has four pictures framed by red lines. The height of each picture is basically the same as that of the tomb wall itself, and the width varies between 0.70 and 0.80m.

## 2. Line Engravings

They are mostly located on the door lintel of the tomb door, on the door frames, and on the stone couch with enclosing screen. They are mostly line engravings interspersed with a few carvings in low relief; gilding is also applied to the pictures.

### Carvings on the door lintel:

In the middle is an animal mask flanked on either side by a winged dragon facing the animal mask. The dragons are in a running pose. Between the dragons and the animal mask are what seem to be flame motifs. The tail of the dragon on the right is also decorated with flame motifs.

### Carvings on the door frames:

Both door frames seem to have identical pictorial images. At the top is a line engraved image of Scarlet Bird facing the tomb entrance. It is spreading its wings as if ready to take flight. The picture immediately below is not legible, and below that are Figures of door guardians. The Figure on the left is more legible; sporting a long beard, he wears a small hat on his head, and his body is clad in a long robe with wide sleeves, tied with a sash at the waist. His feet are clad in shoes with pointed tips and his two hands are holding long swords in front of the body. The door frame on the right is damaged and the upper part of the door guardian Figure is no longer legible. Wearing a long robe with wide sleeves, he seems to be joining his hands together in front as if making a greeting gesture. His feet are clad in shoes with pointed tips.

### Line engravings on the enclosing screen of the couch:

There are a total of ten pictures, with six on the back panels and two on each side panel. The subject of these pictures mainly concerns receiving guests and undertaking excursions.

The south picture on the west side panel— The picture is 73cm high and 39cm wide. It depicts a scene of the male master receiving guests. At the very top of the picture are floating clouds, and below that is a willow tree

with two birds perched on top. The master on the left side of the picture is an old man sitting upright on a square couch. He wears a small hat with flat top on his head, and his body is clad in a long robe with wide sleeves. Placed over both knees is a bolster cushion, and the master's shoes are placed underneath the couch. Five attendants are standing next to the master; they all wear robes with round collars and narrow sleeves. Three of them are carrying feather banners with extended handles, and their heads are wrapped in headscarves. As for the other two attendants, one is holding with both hands a tablet-shaped object, and the other attendant, with only his head shown, is wearing a small hat on his head. To the left of the tree branch is a Figure clad in a short tunic with narrow sleeves and round collar, and his hands are joined in front as if making a gesture of presenting the guests behind him. To the right are six Figures who appear to be guests. They all wear robes that are loose around the shoulders with an overlapping opening in front. Two Figures in front wear hats shaped like houses. They carry with both hands round trays that are partially gilded; they seem to be playing the leadership role among the guests. Behind them are four Figures all wearing on their heads tall round hats with flat tops, and their bodies are clad in robes with overlapping opening in front and wide sleeves. They appear to be standing at attention with both hands joined together in front of the body. At the bottom of the picture are a flowing stream, mountains and rocks, flowers and plants, etc. (Figure 7 left & Figure 8).

The north picture on the west side panel – The picture is 73cm high and 39cm wide. It depicts a scene of the mistress receiving her female guests. On top of the picture are distant mountains and floating clouds, with four swallows spreading their wings and soaring among the clouds. On the left corner there appears to be a willow tree. To the right are mountains and forests, and the forests have dense vegetation. A wild beast is just about to run away from the valley. The mistress is receiving her female guests under the tree. The mistress is kneeling on a square couch, her hair is combed into three chignons, her body is clad in a robe with wide sleeves and an overlapping opening in front. Her tall boots with pointed toes are placed underneath the couch. Behind her are three female attendants with their hair combed into Y-shaped chignons; they wear long robes with wide sleeves and overlapping opening in front. The female attendant next to the mistress is wearing a short garment with narrow



Figure 7. Line Drawing of the West Side Panel of the Screen

sleeves and round collar. With one hand grasping a tree branch, her other hand is resting at the waist in an akimbo pose. On the right are two female guests kneeling on couches. Their hair is combed into three chignons, and their bodies are clad in long robes with overlapping opening in front and wide sleeves. Their faces are turned towards the mistress. Behind the mistress are three female attendants with their hair combed into Y-shaped chignons and clothed in long robes with overlapping opening in front. They are carrying objects in front of them with both hands. Below are mountains, rocks, flowing stream, flowers and plants, and beast running among the mountains and rocks (Figure 7 right & Figure 9).

The first picture from west to east on the back panel – The picture is 73cm high and 27cm wide. The subject concerns the mistress receiving female guests. On top of the picture are a few clouds, a mountain range on the right, and a weeping willow tree on the left. In the middle right is the mistress. Her hair is combed into multiple chignons, her body clad in a long robe with overlapping opening in front, loose around the shoulders, and cinched at the waist by a belt. She is kneeling on a square couch, and her tall boots with pointed toes are placed underneath the couch. Behind her is a female attendant with her hair styled into a Y-shaped chignon; she is holding a fan in her hand. To the right is a female attendant, her





*Figure 8. The South Picture on the West Side Panel of the Screen (Detail)*



*Figure 9. The North Picture on the West Side Panel of the Screen (Detail)*



hair combed into a Y-shaped chignon with a shimmering headdress stuck on top; she is holding a fan in her hand. Another figure with her hair combed into a Y-shaped chignon decorated with flowers is carrying a gift box with both hands. Only the upper torso of another figure is shown. At the bottom of the picture are rocky hillsides, flowers and plants (Figure 10 left & Figure 11).

The second picture from west to east on the back panel – The picture is 73cm high and 30cm wide, and the subject concerns a procession. At the top of the picture is a tree with a banana-like fruit hanging from it. Among the tree branches is a bird. The master is depicted below riding on a horse. He is an old man wearing a robe that is loose around the shoulders with an overlapping opening in front. Next to the master are eight attendants. The groom leading the horse in front is wearing a small hat on his head, and his body is clad in a short tunic with

round collar and long trousers, and his feet are shod in shoes with pointed toes. Holding feather banners are three figures; two of them with small hats on their heads are clad in short tunics with either a round collar or an overlapping opening in front. One figure is wearing a round tall hat on his head. Four other figures are wearing round tall hats on their heads and their bodies are clad in robes with overlapping opening in front and are loose around the shoulders. At the bottom of the picture are rocky hillsides, aquatic plants, and a flowing stream (Figure 10 middle & Figure 12).

The third picture from west to east on the back panel – The picture is 73cm high and 30cm wide, and the subject concerns the mistress taking a walk on foot. At the top of the picture are distant mountains and floating clouds on the right, and a weeping willow tree with one bird perched on top of the tree branch on the left. In the



*Figure 10. Line Drawing of the West Three Pictures of the Back Panel of the Screen*



middle of the picture is a mountain on the right. On the left is the mistress. She is statuesque in built, and her hair is combed into multiple chignons pinned with a shimmering hair ornament on top. Her body is clad in a long robe that is loose around the shoulders and has an overlapping opening in front. A feather fan is held in her two hands hidden inside the sleeves. She is accompanied by six female attendants at her side. They all have their hair styled into Y-shaped chignons, and their bodies are clad in long robes that are loose around the shoulders and have overlapping openings in front. One figure is holding a round fruit tray inside of which is a fruit shaped like a peach. Two figures are carrying rectangular fruit trays, two figures are holding round fans with long handles, and one figure is carrying a floral canopy with a bent handle. The floral canopy is decorated with a long-tailed phoenix ornament at the apex and tassels dangling down the entire rim. At the bottom of the picture are rocky hillsides and aquatic plants (Figure 10 right & Figure 13).

The fourth picture from west to east on the back panel – The picture is 73cm high and 31cm wide, and the subject concerns a brief repose in the middle of a procession. On top of the picture to the left is a mountain range with trees and woods, and to the right is a weeping willow. In the middle of the picture is an ox cart parked with the double shafts propped up by two stands. It has two covers; the lower cover is like a shed with a curved roof, and the upper cover is like an awning. The interior of the carriage is decorated with patterns of circles, flowers and plants. To the right of the cart are two Central Asians kneeling down on the ground. Both of them have cropped hair. The master's chin is somewhat more pointed, and his body is clad in a long robe with round collar, buttons down the front and narrow sleeves. He is beardless. The servant has a long beard and his body is clad in a long robe with round collar and narrow sleeves. His right hand is holding a ewer with a narrow neck and



*Figure 11. The First (Westest) Picture on the Back Panel of the Screen (Detail)*



*Figure 12. The Second (from West) Picture on the Back Panel of the Screen (Detail)*



*Figure 13. The Third (from West) Picture on the Back Panel of the Screen (Detail)*

his left arm is raised with a wine cup in his hand as if proposing a toast. An ox is lying down on the ground and feeding. At the bottom of the picture are rocky hillsides, flowers and plants (Figure 14 left & Figure 15).

The fifth picture from west to east on the back panel – The picture is 73cm high and 26cm wide. The subject concerns a banquet. At the top of the picture is a weeping willow. In the middle is a house with a gable roof built on a high terrace. The terrace is surrounded on all four sides

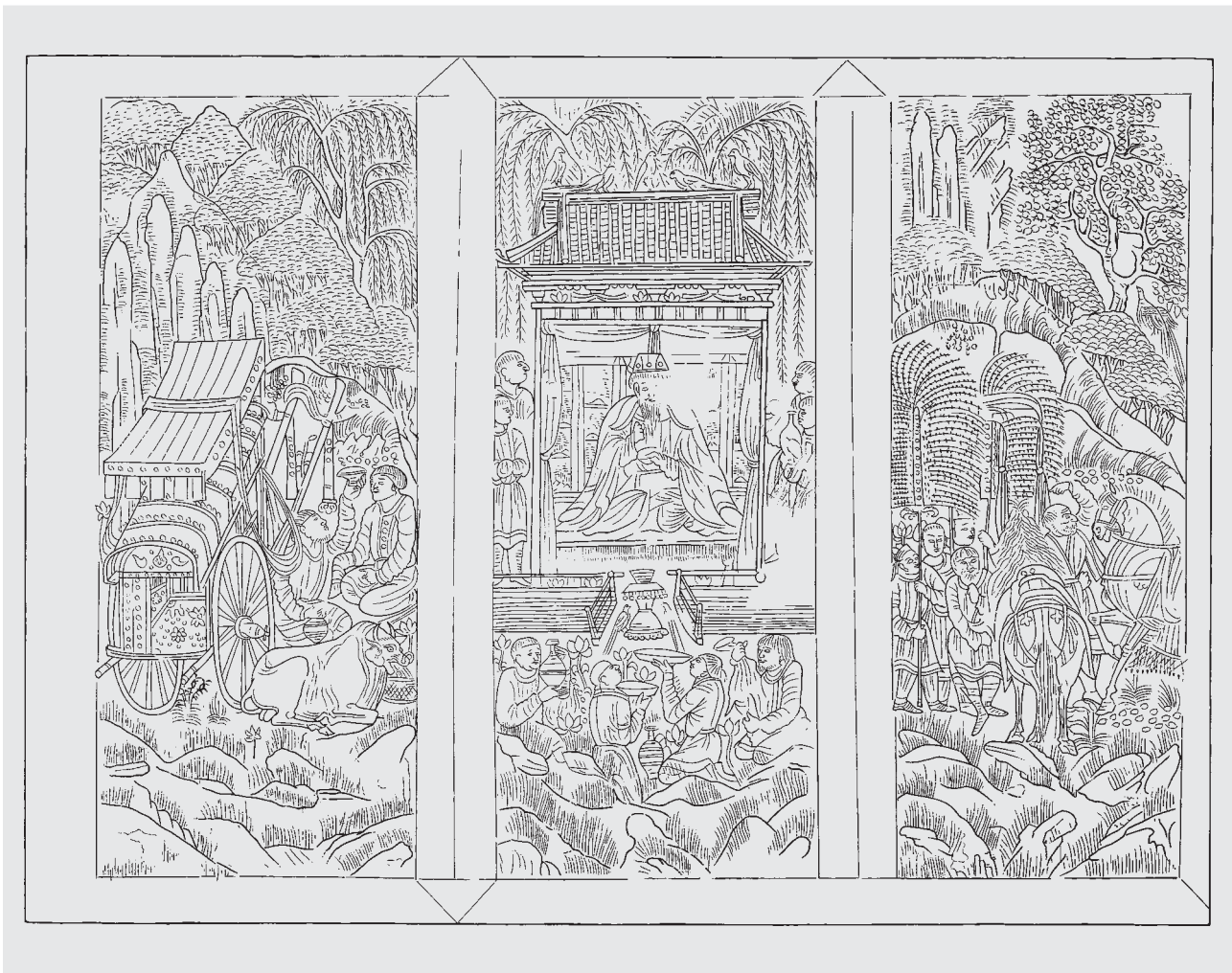

*Figure 14. Line Drawing of the East Three Pictures of the Back Panel of the Screen*



by a fence. The roof of the house has engraved lines showing plank tiles as well as tubular tiles. Perched along the main ridge of the roof are five long-tailed birds. Engraved lines also show wooden beams and brackets underneath the eaves of the house. Curtains that are lifted open can be seen on either side of the door. The back wall in the house interior is adorned with four or five landscape paintings. The master is kneeling on a low dais. He wears on his head a hat shaped like the roof of a house. Sporting a long beard, he wears a long robe with round collar and narrow sleeves and a loose overcoat. His left hand is holding a bowl and his right hand seems to be grasping something. On either side of the door are two Central Asian attendants. Both have cropped hair and they wear short tunics with round collars. The attendant on the right is holding a ewer with a narrow neck. Placed in the middle of the threshold in front of the building is an incense burner. The incense burner has two parts, a top and a bottom. The top is shaped like a basin with a flared lip, and the bottom is a

short base with a narrow mid-section. A long-tailed bird is perched on either side of the incense burner. At the bottom of the picture are four Central Asians clad in long garments with round collars and narrow sleeves. Their hair is long and hanging loose, cropped short, or covered by a round cap as headdress. Some appear to be kneeling on the ground. They are holding respectively a wine cup with a pointed end (*rhyton*), a metal bowl, a ewer with narrow neck, etc. (Figure 14 middle; Figures 16 & 17).

The sixth picture from west to east on the back panel – The picture is 73cm high and 29cm wide, and the subject concerns a procession. The top of the picture depicts rows of mountains and forests. There is a large tree on the right and below the tree is a long-tailed bird. In the middle section of the picture to the left are three attendants who do not appear to be Central Asians. They are all holding long-handled feather banners and feather fans. One of them has a headscarf wrapped around his head, and his body is clad in a short tunic with round



Figure 15. The Fourth (from West) Picture on the Back Panel of the Screen (Detail)



Figure 16. The Fifth (from West) Picture on the Back Panel of the Screen (Detail, one of two)

collar and narrow sleeves. One figure with hair combed into a Y-shaped chignon appears to be a woman but only her face is shown. Both figures leading horses are dressed in Central Asian costume. One figure has cropped hair, sports a beard and wears a short tunic with round collar and narrow sleeves, and his feet are shod in boots with pointed toes. The other figure is bald, has a long nose, and sports a short beard. His body is clad in a long robe with an opening down the front. There are two horses fully geared up with saddle and bridle. At the bottom of

the picture are rocky hillsides, flowers and plants (Figure 14 right & Figure 18).

The north picture on the east side panel – The picture is 73cm high and 39cm wide, and the subject concerns the mistress receiving her female guests. At the top of the picture there are distant mountains and floating clouds on the left and a weeping willow on the right. In the middle section of the picture to the left is the mistress kneeling on a square couch, her hair combed into multiple chignons, and her body clad in a long jacket

with an opening that overlaps in front and is loose around the shoulders. Her long boots are placed in front of the couch. Three female attendants are standing behind and beside her. They all have their hair combed into Y-shaped chignons, and their bodies are clad in long jackets with overlapping opening in front and loose around the shoulders. One of them is holding a fan, another is standing at attention with both hands joined together in front, while the third one is stretching both arms in front as if receiving gifts brought by the guests. The female guest is seated on a low dais, her hair combed into multiple chignons, her body clad in a long jacket with overlapping opening in front and loose around the shoulders. She is holding with both hands a round tray. Three female attendants are standing behind and beside. They all have their hair combed into Y-shaped chignons, their bodies clad in long jackets with an opening that overlaps in front and loose around the shoulders. They are joining both hands in front and standing at attention. At the bot-



*Figure 17. The Fifth (from West) Picture on the Back Panel of the Screen (Detail, two of two)*



*Figure 18. The Sixth (Eastest) Picture on the Back Panel of the Screen (Detail)*





Figure 19. Line Drawing of the East Side Panel of the Screen

tom of the picture are rocky hillsides, a flowing stream, flowers and plants, and a wild beast is standing on the bank of the stream (Figure 19 left & Figure 20).

The south picture on the east side panel – The picture is 73cm high and 39cm wide. The subject concerns the mistress receiving her female guests. At the top of the picture are birds in flight, floating clouds and distant mountains. In the middle section of the picture to the left is a large tree, and to the right is a mountain range. The mistress is kneeling on a square couch under the tree. Her hair is combed into a Y-shaped chignon, her body is clad in a long jacket that is worn loose around the shoulders. Her tall boots are placed in front of the couch. Behind and on either side are five standing female attendants.

They all have their hair combed into Y-shaped chignons, their bodies are clad in long jackets with overlapping opening in front and loose around the shoulders. Two of them are holding fans, one is carrying a round tray, and two are standing at attention. Two female guests are kneeling on a low dais. They both have hair combed into multiple chignons, and wear long jackets with overlapping opening in front and loose around the shoulders. Four female attendants are standing next to them; they all have hair combed into Y-shaped chignons and wear long jackets with overlapping opening in front and loose around the shoulders. One of them is carrying a rectangular box, and three of them with hands joined together in front are standing at attention. At the bottom are rocky slopes, flowing



*Figure 20. The North Picture on the East Side Panel of the Screen (Detail)*



*Figure 21. The South Picture on the East Side Panel of the Screen (Detail)*



*Figure 22. The Animal Head Line Engraving in the Middle of the Obverse of the Couch Platform*

stream, flowers and plants, and on the bank of the stream is a wild beast drinking water (Figure 19 right & Figure 21).

Line engravings on the couch platform:

They are mostly located on the front and on both sides of the couch platform. The pictorial arrangement is basically the same. Along the top and bottom are two rows of linked pearls, at the center are wavy patterns of lotus blossoms with intertwining stems, and the surrounding empty space is filled with designs of animals, clouds and mists, lotus leaves, etc. The ornamentation on the front of the couch platform consists of an animal head in the middle; the face is painted green and it has sharp teeth. It is similar to the animal mask in the middle of the door lintel. On either side of the animal mask are symmetrical images of the Four Supernatural Beings: Scarlet Bird, White Tiger, Green Dragon and Sombre Warrior. Below the peaks of the waves are patterns of lotus leaves and lotus blossoms. Among the Four Supernatural Beings, White Tiger is most peculiar as it does not resemble a tiger; one of them looks more like a lion, and the other looks more like a monstrous beast. The empty space surrounding the stemmed lotuses on the left is filled with stylized lotus leaves and animal motifs. The animals are a mountain goat, a camel and a ferocious beast. The bodies of the animals are mostly hidden behind the stylized patterns of lotus leaves, clouds and mists. The design on the right is similar to that on the left, with the exception that the animals are a rooster, a ferocious tiger, a monstrous beast and a phoenix-like bird (Figures 22–25).

### **Concluding Remarks**

The tomb of Kang Ye is the third Sogdian burial found in the vicinity of Xi'an. According to the tomb epitaph, the tomb occupant's name is Ye 厓, and his cog-



nomen is Yuanji 元基. He was a descendent of the royal lineage of the Samarkand Kingdom. His father was appointed Grand Heavenly Master in the tenth year of the Datong era of the Western Wei (544 CE), and he passed away in the third year of the Baoding era of the Northern Zhou (563 CE). Ye succeeded as the next Grand Heavenly Master, and he passed away in the sixth year of the Tianhe era of the Northern Zhou (571 CE) at the age of sixty. He was posthumously granted the title of Governor of Ganzhou. Ye had three sons.

The material remains excavated from the tomb and the content of the line engravings reflect the friendly exchanges between East and West during the Northern Dynasties. The excavated gold coin was struck during the reign of Justinian of the Eastern Roman Empire. The ancestors of the tomb occupant were from Samarkand. The Samarkand Kingdom is located in present day Samarkand on the south bank of the Zerashan River; as one of the Central Asian kingdoms with the nine surnames of Zhaowu, it once occupied a supreme position throughout the region of Sogdiana. People from Samarkand had deep-set eyes and high-bridged noses, grew beards and were adept in commercial transactions. The men cropped their hair, their women styled their hair into chignons, and they believed in Zoroastrianism and Buddhism. The tomb occupant's eldest son and second son are named respectively as "Bianxiuyan 派休延" and "Pantuo 槃随", typical Central Asian names. The third son was named "Huozhu 货主", a name related to commercial trading. This exemplifies the character of Sogdians as being "adept in trade and business."

Among the line engravings on the enclosing screen, three pictures that particularly reflect the activities of Central Asians are pictures 4, 5, and 6 on the back



*Figure 23. The Scarlet Bird Line Engraving on the Obverse of the Couch Platform*



*Figure 24. The White Tiger Line Engraving on the Side of the Couch Platform*



*Figure 25. The Mountain Goat Line Engraving on the Side of the Couch Platform*

panel. Most of the Figures depicted have cropped hair and their bodies are clad in long tunics with round collars and narrow sleeves; some wear long robes with openings in front. Furthermore, the linked pearl motif along the sides of the couch platform is of foreign stylistic origin. The pictorial composition of the line engravings has an unusual characteristic in that the pictorial space is systematically divided into three or four parts from top to bottom. The top part shows mountains, floating clouds, flying birds, etc. that are freely sketched out in order to capture the impression of being at a distance. Behind the Figures are usually steep mountains and big trees that are naturalistically depicted, and the branches and leaves of the trees in the mountains are all vividly delineated in detail. Most of the human activities occur in front of mountains or beneath trees. Every detail of hairstyle, costume, pose and facial expression is convincingly portrayed and brought to life; they constitute the close-up view that is also the main subject of the picture. The bottom part usually consists of rocky hillsides, flowing stream, flowers and plants, etc. These are the closest views. From top to bottom, from far to near, everything is in proper scale and order. The proportion of each part in relation to the total picture space

also varies. Distant mountains and floating clouds are usually allotted proportionally the smallest space; sometimes they are shown merely within narrow cracks in the picture. The background mountains and trees occupy proportionally the most space, taking up to four tenths of the picture space. In some cases, they take up half the picture space while people and their activities take up one third of the picture space. As indicated by the proportional space of each part, people take up approximately one third of the picture space. It is not difficult for one to realize that the artist pays much attention to the setting in which human activities take place. The Three-Kingdoms to the Southern and Northern Dynasties was the burgeoning period in the development of Chinese landscape painting. Although there are many written records concerning landscape painting, it is rare to find examples of landscape painting as independent subjects. While the line engraved pictures on the enclosing screen of the couch in this tomb cannot be considered as landscape painting as such, the thorough manner in which the setting of human activities (trees, plants, mountain ranges, clouds, etc.) is represented constitutes an important stage in the rise and development of landscape painting.

Postscript: The original report was published in *Wenwu* 文物 (Cultural Relics) 2008. 6: 14–35. There are 32 illustrations with 18 photographs and seven ink rubbings. The present version was authored and rewritten by Cheng Linquan 程林泉 and Zhang Xiangyu 张翔宇, translated into English by Judy Chungwa Ho.