

2006 Excavation of Eastern Zhou Tombs in Dapuzishan Mountain Region in Lixian County, Gansu Province

Collaborative Archaeological Team of the Early Qin Culture

Key words: Lixian (Gansu Province) Qin Culture Burials

To further explore the early Qin Culture and look for the locations of “Xi Quanju 西犬丘” and “Qin Ting 秦亭”, the early capitals of Qin, since the year 2004,

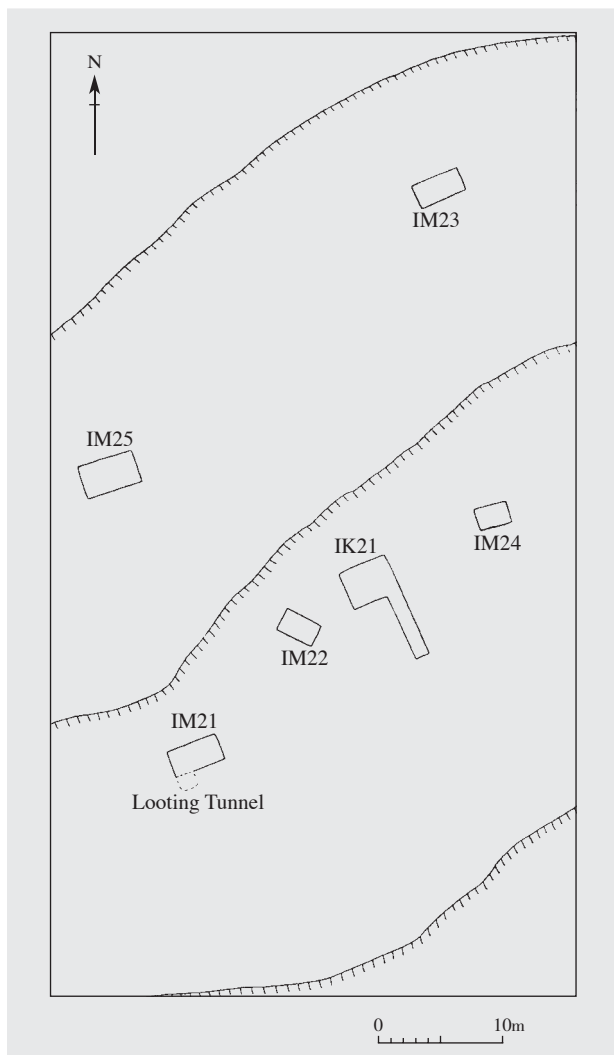

Figure 1. The Excavated Tombs in Quadrant I of Dapuzishan Site

Gansu Provincial Institute of Cultural Relics and Archaeology, together with School of Archaeology and Museology, Peking University, National Museum of China, Shaanxi Provincial Institute of Archaeology and School of Culture and Museology, Northwest University, organized the joint project group and started the survey, excavation and research projects on early Qin Culture.

In September through November 2006, the Dapuzishan Site was excavated as a part of the early Qin Culture exploration project; the excavation recovered nine tombs and one chariot and horse pit, the IIM1, IIM2 and IM25 were better preserved but the others were severely looted.

I. The Locations of the Tombs and the Stratigraphical Relations

Dapuzishan Site is located on the north bank of West Han River, where West Han River receives Yongping River, a tributary of it flowing from north. The terrain to the northeast of the site is multi-stepped terraces at present; the south side of the terraces becomes gentler and gentler to the south and on the north bank of West Han River (their south margin) the terrain was almost flat. The medium- and small-sized tombs are mainly distributed outside the northeastern city wall discovered in the survey.

In this excavation, Dapuzishan Site is divided into four quadrants; the excavated tombs are mainly concentrated in Quadrants I and III. The colors and textures of the soils in the two quadrants are slightly different: Quadrant I has sowing soil stratum, disturbed stratum and primary soil stratum; the openings of Tombs IM21 to IM25 and Chariot and Horse Pit IK21 are all found beneath the disturbed stratum (Figure 1). The accumulation of Quadrant III con-

sists of sowing soil stratum, disturbed stratum, late Spring-and-Autumn stratum and primary soil stratum; the openings of Tombs IIM1 and IIM2 are found beneath the late Spring-and-Autumn stratum.

II. The Tomb Types and Grave Goods

All of the excavated tombs are earthen vertical shaft tombs, and can be assorted into Group A (in east-west orientation) and Group B (in north-south orientation).

1. Group A. Four of them have been excavated (IM21, IM23, IM24 and IM25), two of which (IM23 and IM25) have a recess on the wall, respectively. Now the IM25 is taken as the example.

IM25 is in an orientation of 245° and a roughly trapezoid plan; the opening is 4.8m long, 2.4m wide at the east side and 2.7m wide at the west side; the opening is discovered 0.8m below the present ground and the whole tomb is 8.5m deep. The four walls are straight and smooth, and the bottom is flat. The tomb is filled with mottled brownish-yellow earth with hard texture. The recess is at the eastern part of south wall, the top of which is in an irregular arch shape and 7.72m below the ground. The recess is 0.58m high, 1m wide and 0.24m deep. It is filled with mottled earth and a few animal bones are found in it.

The second-tier terraces surrounding the coffin chamber were 8.3m below the tomb opening and 1m high. The terrace on the east side is 0.3m wide, those on the west and north are 0.5m wide and that on the south side, 0.45–0.54m wide. Only the second-tier terrace on the south side is well preserved, and those on the other three sides have all collapsed somehow. The tomb was furnished with one outer coffin and one inner coffin; the outer coffin is in rectangular plan, the length of which is 4m, the width, 1.7m and the height, 1m. The roof of the outer coffin was composed of 17 wooden boards in north-south direction; the boards were 1.85–2.1m long, 0.16–0.3m wide and about 1.2cm thick

(Figure 2 Top). In the west part of the outer coffin roof, the skeleton of an accompanying dog is found. The inner coffin was also in rectangular shape and placed in the middle of the outer coffin slightly to the east; it was 1.9m long and 0.76m wide. In the southwest corner of the inner coffin, large amount of stone slats made into the shape of *gui*-scepters and in various sizes are found, all of which bear no decorative patterns (Figure 4). The skeleton of the tomb occupant has rotten, but the burial position is identifiable: he is heading west and facing south in a flexed supine position with the hands folding on the chest (Figure 5). A head chamber is set in the west end of the outer coffin, which is in rectangular shape 1.7m long, 1.44m wide and 1m high. 13 pieces of grave goods are yielded in the head chamber, including three bronze *ding*-tripods, one bronze *yu*-vessel, one *yan*-steamer, six pottery jars and two pottery *dou*-stemmed bowls. Below the floor board of the outer coffin, an oval

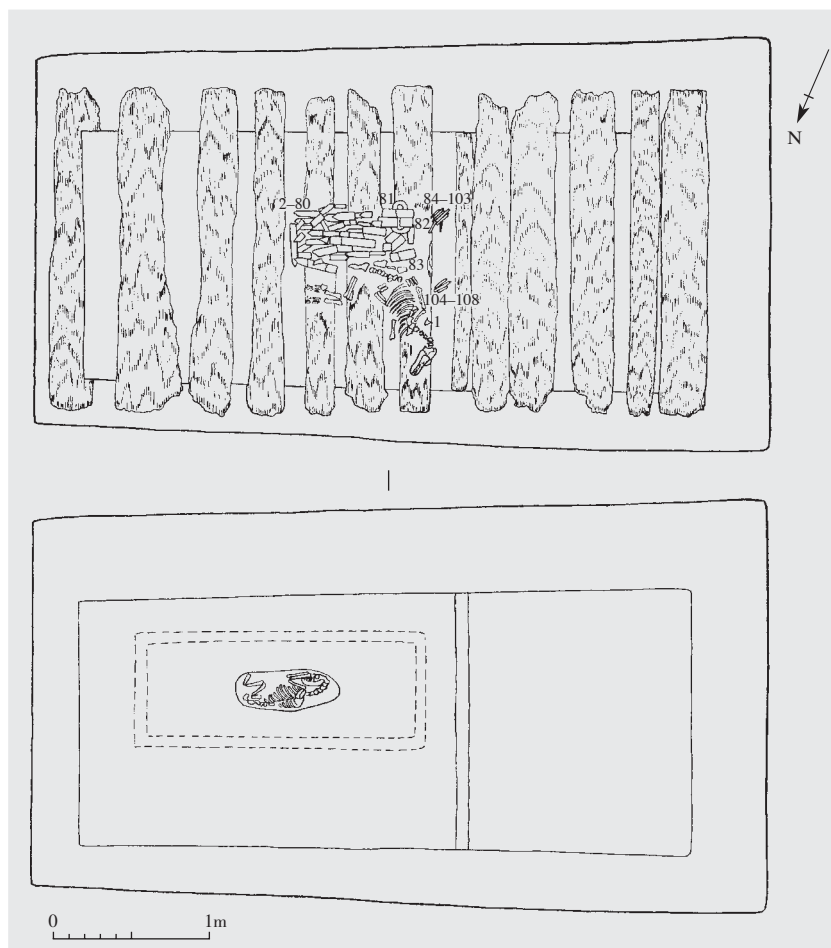

Figure 2. The Plan of the Cover Boards of the Coffin Chamber and the Waist Pit of IM25
1. bronze bell at the neck of the dog skeleton 2–80. stone *gui*-scepters 81 and 82. stone *bi*-disc 83. stone shovel 84–117. small stone *gui*-scepters

waist pit 0.68m long in major axis, 0.25m wide in minor axis and 0.1m deep is found, in which the skeleton of an accompanying dog is buried (Figure 2 Bottom).

In total 153 pieces of grave goods are found in IM25, including bronzes, jade and stone objects and potteries (Figure 3).

Bronzes. 8 pieces, including *ding*-tripods, *yu*-vessel, *yan*-steamer, ring, tiger, dagger and bell.

One cooking *ding*-tripod (IM25:148). Rectangular straight ears stand on flat rim, the bottom is round and three hoof-shaped legs are attached. The upper part of

the belly is decorated with a register of interlaced hydra design and the lower part with a register of the combination of interlaced hydra and wave designs, and the upper parts of the legs are also decorated with interlaced hydra design. The entire ware is 14.1cm high and 16.1cm in rim diameter (Figures 6:1 and 7).

Two serving *ding*-tripods (IM25:149 and IM25:147). They are in same shape but different sizes, both of which are plain without decorative patterns. IM25:149 has straight ears on the rim, shallow belly, flat bottom, hoof-shaped legs. Three casting-fins are seen on the outer surface of the bottom. It is 10.6cm high and 12.2cm in rim diameter (Figure 6:2). IM25:147 is 12.3cm high and 14.3cm in rim diameter (Figures 6:4 and 8).

One *yu*-vessel (IM25:150). It has a lid with a disk-shaped knob. The vessel has flat rim, restricted neck, bending shoulder and small ring foot. The entire body is decorated with interlaced hydra design and the lid is also decorated with a register of interlaced hydra design. It is 18.4cm high and 19.8cm in rim diameter (Figures 6:3 and 9).

One *yan*-steamer (IM25:141) is composed of *zeng*-steamer on top and *li*-cauldron on the bottom. The *zeng*-steamer has rectangular mouth and rectangular side ears; on the bottom are there three rows of grate slots but not pierced. The *zeng*-steamer and *li*-cauldron are fitted with "mother-and-child" rims. The *li*-cauldron has straight ears, separated crotches, flat bottom and four hoof-shaped legs. The *zeng*-steamer is decorated with five registers of interlaced hydra design and the shoulder of the *li*-cauldron is decorated with one register of interlaced hydra design. The entire ware is 37cm high, the mouth of the *zeng*-steamer is 20.8cm long and 15.8cm wide (Figures 6:5 and 10).

One ring (IM25:131). The outer diameter is 1.45cm and the inner

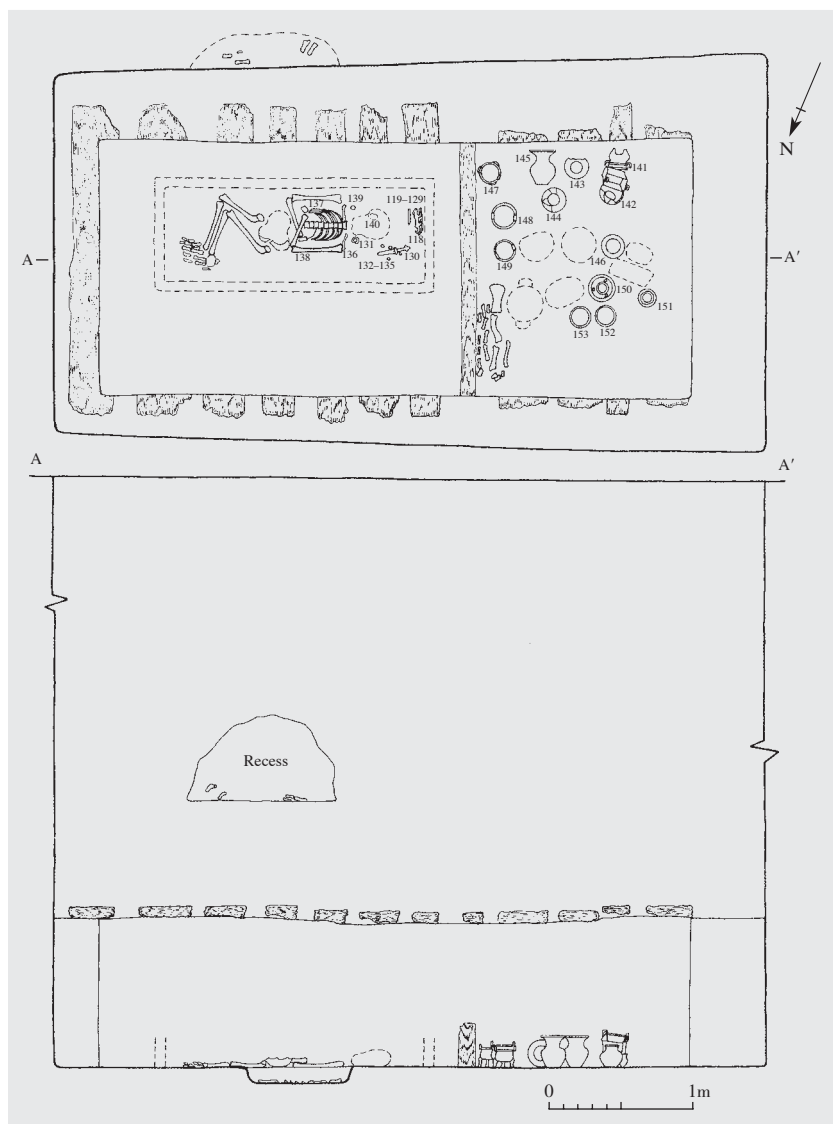

Figure 3. The Plan and Section of IM25

118. bronze tiger 119-129. stone *gui*-scepter 130. bronze dagger 131. bronze ring 132-135. jade rings 136 and 139. jade *jue*-pendant 137 and 138. jade ornaments 140. jade cicada 141. bronze *yan*-steamer 142-145. pottery jars with trumpet-shaped rim 146. Pottery basin 147-149. bronze *ding*-tripods 150. bronze *yu*-vessel 151. pottery jar 152 and 153. pottery dou-stemmed bowls

diameter, 0.9cm.

One bronze tiger (IM25:118). In squatting pose, a unit of interlaced hydra design is decorated in the middle of the body. The tail is curling upward into a semi-circle, and the inner side of the tail is also decorated with interlaced hydra design. A button is on the tiger's back. The whole tiger is 5.85cm long and 1.5cm wide (Figure 11).

One dagger (IM25:130). The blade is in the shape of a willow leaf and the central ridge is in the shape of a column; the guard and pommel are all much wider than the hilt; the blade has an iron tang inserted into the bronze hilt. The guard, hilt and pommel are all decorated with interlaced hydra designs made in openwork as a whole; the interlaced hydra designs on the hilt are stretching to the left and right sides, forming six serrations. The guard and pommel are all made into external and internal layers which can be seen through the openwork. The whole dagger is 20.6cm long (Figure 12).

One bell (IM25:1). The cross-section is in the shape of an almond and the entire body is plain without decorative patterns. A pestle-shaped clapper is hung inside the bell. The remaining height is 3.8cm and the width is 2.55–2.61cm.

Potteries. Eight pieces are unearthed from IM25.

Two *dou*-stemmed bowls (IM25:152 and 153). They

are made of fine gray pottery and in the same shape: flared mouth, shallow bowl body with bending wall on trumpet-shaped ring foot. Both have no decorative



Figure 4. IM25 (NE-SW)



Figure 5. Full-view of IM25 (Top is Northwest)

patterns. IM25:152 is 10.2cm high and 13cm in bowl diameter (Figure 13:4) and IM25:153 is 10cm high and 12.8cm in bowl diameter (Figure 13:5).

Jars with trumpet-shaped rim. Four pieces are found in IM25. All are made of sandy gray pottery with flared mouth, contracted neck, swelling belly and flat bottom.

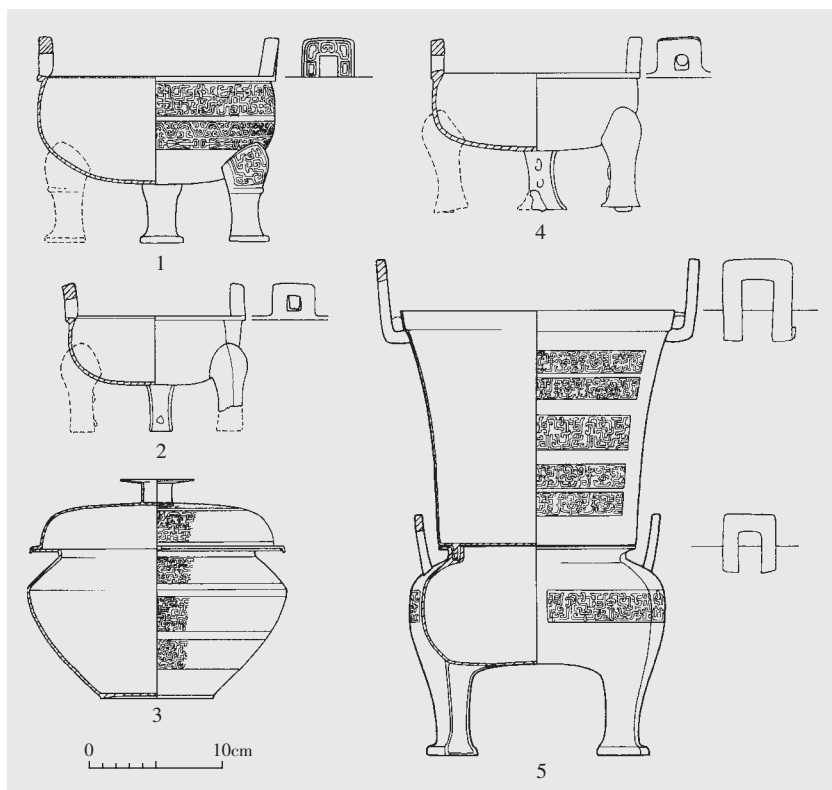

Figure 6. Bronzes from IM25

1, 2 and 4. ding-tripod (IM25:148, 149 and 147) 3. yu-vessel (IM25:150) 5. yan-steamer (IM25:141)

Thick vertical cord patterns are decorated in the belly. Sample IM25:143 has smeared cord pattern below the rim, and three rings of bowstring patterns on the neck and shoulder, respectively. It is 25cm high and 18.8cm in mouth diameter (Figure 13:8). Sample IM25:145 has similar shape with the former one, but has two symmetrical ring-shaped lugs on the shoulder; four rings of bowstring patterns are on the neck and three are on the shoulder, below which are thick cord patterns. It is 19.3cm high and 17.1cm in mouth diameter (Figure 13:3). IM25:142 is 20.4cm high and 17.5cm in mouth diameter (Figure 13:7). IM25:144 has four rings of bowstring patterns on the neck and three on the shoulder, below which are thick cord patterns. It is 24.8cm high and 19.6cm in mouth diameter (Figure 13:6).

One jar (IM25:151). It is made of sandy gray pottery without decorative patterns. It has a flared mouth, contracted neck, bending shoulder, lower belly and flat bottom. It is 9cm high and 6.7cm in mouth diameter (Figure 13:1).

One basin (IM25:146). It is made of fine gray pottery without decorative patterns. It has out-bending rim, clear ridge on the inner side of the rim, slightly swelling belly and flat



Figure 7. Bronze Ding-tripod (IM25:148)



Figure 8. Bronze Ding-tripod (IM25:147)



Figure 9. Bronze Yu-vessel (IM25:150)



Figure 10. Bronze Yan-steamer (IM25:141)



Figure 11. Bronze Tiger (IM25:118)



Figure 12. Bronze Dagger (IM25:130)

bottom. It is 13.2cm high and 18.4cm in rim diameter (Figure 13:2).

Jade and stone objects, 10 pieces in total are unearthed from IM25.

Stone *bi*-discs, two of them are unearthed. IM25:82 is in white color with greenish tint; the diameter is 6.8–7cm and that of the central hole is 2cm. IM25:81 is in ivory white color, the diameter of which is 8cm and that of the central hole, 2.2cm.

One stone adze (IM25:83) is found, which is made of bluish-gray stone into an elongated trapezoid shape and with unilateral blade. The remaining length is 8.8cm and the width is 3.6cm.

Jade *jue*-pendants, two pieces of them are unearthed. They are made of ivory white jade and processed roughly. IM25:136 is 3.2cm in diameter and the central

hole is 0.9cm in diameter. IM25:139 is 3cm in diameter and the central hole, 0.88cm.

In addition, three rings made of yellowish-green jade are found, the diameters of which are 1.1–1.3cm. One cicada made of green jade is also found, which is 1.35cm long. Another fragmentary ornament 3.6cm in remaining length is found, which is made of ivory white jade and with a perforation.

Stone *gui*-scepters, 107 pieces of them are found in IM25, all of which are made with gray or bluish-gray stones, and the cross-section of which are all flat octagonal. They can be assorted into six types by lengths.

Type A: six pieces. 35–39.4cm in length. IM25:11 has a triangle tip and the upper portion is wider than the lower, the whole length of which is 35cm.

Type B: 25 pieces. 25–30cm in length and 3–7.2cm

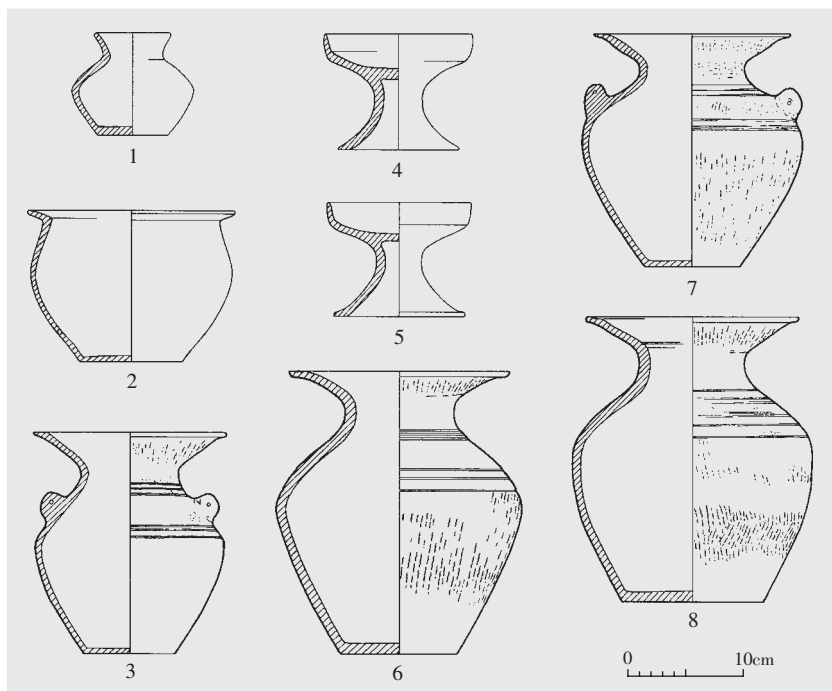

Figure 13. Potteries from IM25

1. jar (IM25:151) 2. basin (IM25:146) 3 and 6-8. jars with trumpet-shaped rim (IM25:145, IM25:144, 142 and 143) 4 and 5. dou-stemmed bowls (IM25:152 and 153)



Figure 14. Stone Gui-scepter (IM25:66)



Figure 15. Stone Gui-scepter (IM25:67)

in width. IM25:66 has a sharp tip and fluent turning from the tip to the body. The whole length is 25cm (Figure 14).

Type C: 18 pieces, 20–24cm in length and 2.5–5.3cm in width. IM25:38 has a sharp tip and the widest part is in the middle slightly to the lower portion, and the cross-section is rectangular with curved corners. The whole length is 24cm.

Type D: 18 pieces. 14.5–19.5cm in length and 2.3–5cm in width. IM25:67 is made of light green jade and has a sharp tip. The whole length of which is 19.1cm (Figure 15).

Type E: six pieces. 10–14cm in length and 0.5–3.5cm in width. IM25:59 has a sharp white tip. The two sides are not in the same width and thickness. The whole length is 11.6cm.

Type F: 34 pieces. 4–8cm in length and 0.6–1cm in width; about 40 pieces of fragments are also attributed to this type. IM25:88 shows weathered yellowish tint, the widest part is at the bottom; the cross-section is irregular quadrilateral. The whole length is 6.85cm.

2. Group B. Three of them have been excavated (IM22, IIM1 and IIM2). Now the IIM1 is taken as the example.

IIM1 is in an orientation of 210° and a roughly rectangular plan; the opening is 4.3m long, 2.34–2.35m wide and the bottom is 4.25m long, 2.34–2.4m wide; the depth of the tomb is 6.3m. surrounding the bottom are the artificial second-tier terraces, the tops of which are 5m below the opening and the height, 1.3m from the bottom. The second-tier terrace on the east side is 0.42–0.48m wide, on the south side, 0.16m wide, on the west side, 0.34m and on the north side, 0.2m wide. The

tomb is furnished with one outer coffin and one inner coffin; the outer coffin is in rectangular plan, the length of which is 3.89m, the width, 1.63m and the height, 0.92m, but it has decayed and caved in. The roof of the outer coffin was composed of 20 wooden boards arranged in east-west direction; the boards were 0.18–0.2m wide. On the top of the roof boards and directly above the position of the head chamber, a wood chariot is found; it is preserved rather well except for the wheel on the west side which is a little damaged. The chariot shaft is heading north, the whole length is 2.43m, the diameters of the wheels are 1.66m and the length of the axle is 2.12m. On the roof board of the outer coffin, the skeleton of an accompanying dog is found. On the bottom of the inner coffin, a thin layer of plant ash is laid. The inner coffin is 1.9m long, 0.6m wide; on the southwest corner of the inner coffin, a stone *gui*-scepter is unearthed. A head chamber is set in the south end of the outer coffin, which is in rectangular shape 1.9m long (north-south) and 0.6m

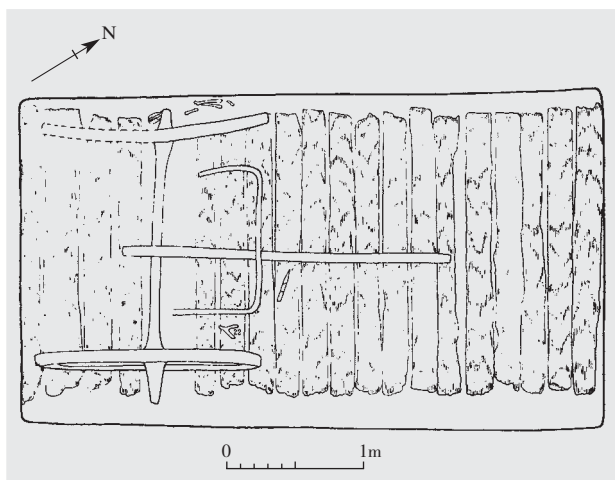

Figure 16. The Plan of the Cover Boards of the Coffin Chamber and the Chariot of Tomb IIIIM1



Figure 18. Full-view of Tomb IIIIM1 (Top is Northwest)

wide (east-west) and 0.92m high. In total 25 pieces of grave goods are yielded from this tomb including bronzes, jade and stone objects, cowries, a deer antler, and so on (Figures 16–19).

Bronzes. 13 pieces are found, including *ding*-tripods, a *yan*-steamer, a sword, an arrowhead and chariot and horse fittings.

Three *ding*-tripods are found in this tomb, all of which are made in similar shape: rectangular straight ears are standing on the flat bending rim, shallow belly, flat bottom, three hoof-shaped legs, no decorative patterns on the bodies. They would belong to a set of *ding*-tripods. IIIIM1:1 has a drilled hole near the ear, the entire vessel is 10.7cm high and 11.75cm in rim diameter (Figures 20:4 and 21). IIIIM1:2 is 13.6cm high and 13cm in rim

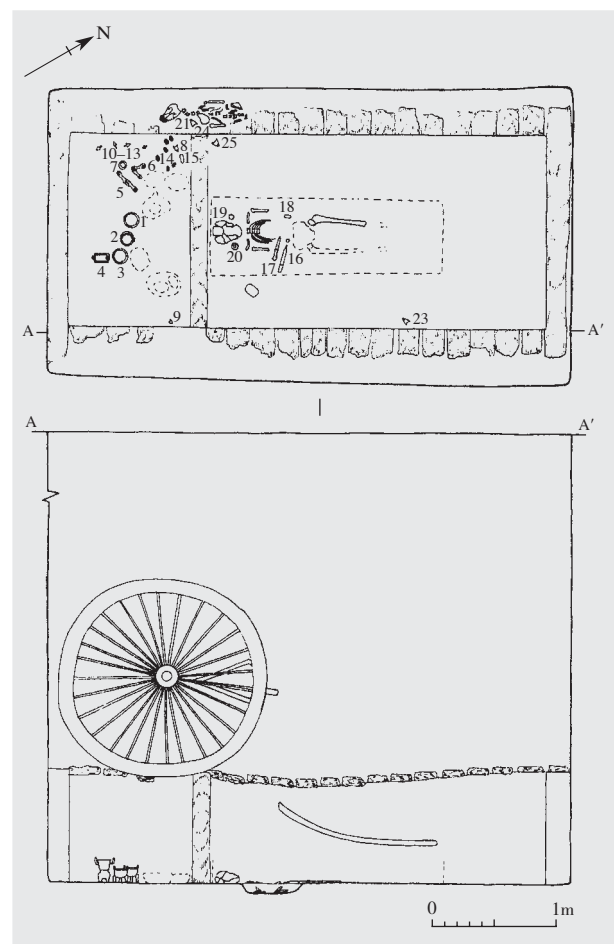

Figure 17. The Plan and Section of Tomb IIIIM1

1–3. bronze *ding*-tripods 4. bronze *yan*-steamer 5 and 6. bronze snaffles 7. bone tube 8, 9, 21, 23 and 25. bronze bells 10–13. bronze arrowheads 14. cowry 15. bone implement 16. stone *gui*-scepter 17. iron sword with bronze hilt 18 and 20. jade *jue*-pendants 19. jade ornament 24. stone implement



Figure 19. The Head Chamber of Tomb III M1 (NE-SW)

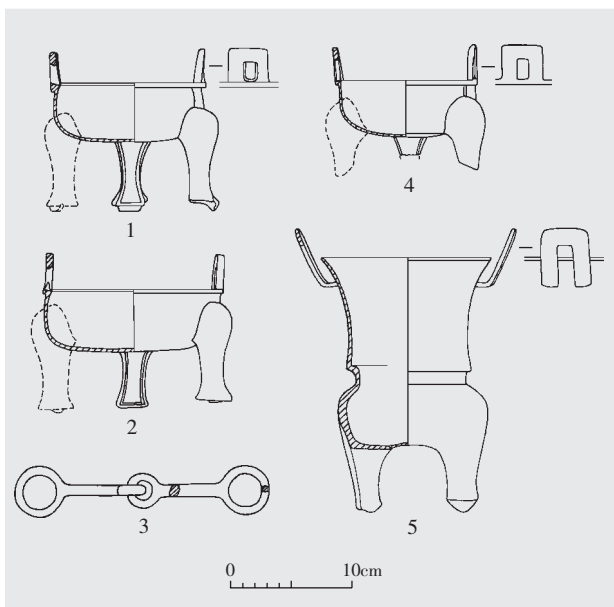

Figure 20. Bronzes from III M1
1, 2 and 4. ding-tripods (M1:2, 3 and 1) 3. snaffle (M1:6) 5. yan-steamer (M1:4)



Figure 21. Bronze Ding-tripod (III M1:1)

diameter (Figures 20:1 and 22). III M1:3 has a slightly swelling belly and three casting fins on the bottom. It is 13.4cm high and 15cm in rim diameter (Figure 20:2).

One yan-steamer (III M1:4). The upper part (*zeng*-steamer) and lower part (*li*-cauldron) are cast as a whole; the mouth of the *zeng*-steamer is rectangular with wide rim beside which two rectangular ears are attached (one of which is missing). No grate is found inside the vessel. The *li*-cauldron has flat bottom and joint crotches and



Figure 22. Bronze Ding-tripod (III M1:2)



Figure 23. Bronze Yan-steamer (III M1:4)

four column-shaped legs. The entire vessel is 23.6cm high, the mouth of the *zeng*-steamer is 14cm long and 10.8cm wide (Figures 20: 5 and 23).

Two snaffles in the same sizes. Each is formed by two identical parts of two rings linked with a bar. IIM1: 6 is 21.2cm long (Figure 20:3).

Five bells. IIM1:8 has a suspension ring on top but the hole is not open; it has ridges in the middle of the two wider sides. Its height is 4.2cm. IIM1:21 has a bridge-shaped suspension ring on the flat top and a clapper cast on the inner top. Its height is 4.1cm. IIM1:25 is in an almond-shaped cross-section, the suspension ring on the top is missing. A square hole is on the top; the two sides are not in the same length. A pestle-shaped clapper is cast on the inner top. Its remaining height is 3.8cm. IIM1:9 has a suspension ring on the top and vertical ridges in the middle of the two wider sides. Its height is 4.9cm (Figure 24).

One iron sword with bronze hilt (IIM1:17). The iron blade has completely rusted, only few fragments and the bronze hilt are preserved. The hilt is 10cm long and decorated with diagonal spiral patterns (Figure 25).

One arrowhead (IIM1:10). It has two wings and a conical tang, the whole length is 4.1cm.

Jade and stone objects and bone, horn and shell implements, 16 pieces in total are yielded from IIM1.

Deer antler, one piece (IIM1:22). It is in a Y-shape.

One stone implement (IIM1:24). It is made of bluish stone in flat trapezoid shape, on the notch on the top of which, cinnabar traces are seen. It is 11.6cm long.

One stone *gui*-scepter (IIM1:16). It is made of white stone into a narrow rectangular shape with a sharp triangular tip. The cross-section of the object is irregular pentagonal. The whole length of this *gui*-scepter is 25.2cm and the width at the widest part is 2.8cm.

Two jade *jue*-pendants. They are made into the shape of ring with a notch from the central hole through the rim. IIM1:20 is 2.75cm in diameter and 0.8cm in the central hole diameter. IIM1:18 is made of reddish brown material with weathering marks. It is 2.7cm in diameter



Figure 24. Bronze Bells (IIM1:8, 9, 21, 23 and 25)

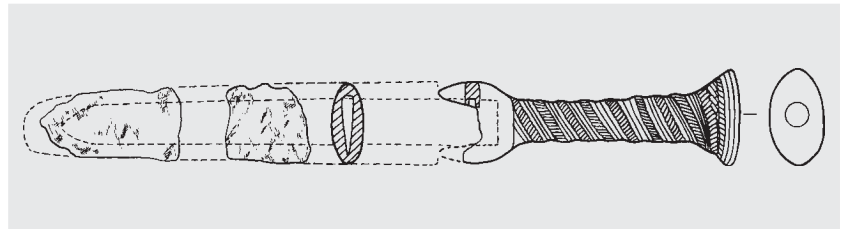

Figure 25. Iron Sword with Bronze Hilt (IIM1:17)

and 0.9cm in the central hole diameter.

One cowry (IIM1:14). Its color is white with cinnabars attached. The whole length is 4cm.

Two bone tubes. IIM1:7 is 2.9cm long and bearing polishing traces.

III. Dates and the Statuses of the Tomb

Occupants

The bronze assemblage of IM25 is three *ding*-tripods, one *yan*-steamer and one *yu*-vessel, which belongs to an incomplete assemblage. The shapes of these bronzes are similar to that from the tombs at Fulinbao Eastern Zhou tombs (M1:6, 5 and 2, see the Paochi Archaeological Team 1963) in Baoji, Shaanxi; the shapes and decorative patterns such as interlocking *leiwen* (lit. “thunder pattern”, square spiral pattern) of the latter are popular styles in the middle and late Spring-and-Autumn Period, as well as the shapes and the interlaced *panhui* (hydra) design are also frequently seen on the bronzes of the middle and late Spring-and-Autumn Period. Moreover, the iron dagger with bronze hilt unearthed from IM25 has similar shape with the iron dagger with bronze hilt from BM27 of Baqitun Eastern Zhou tombs in Fengxiang, Shaanxi (Yongcheng Archaeological Team, Shaanxi Province 1980), and the grave good assemblages of these two tombs are also the same. The

yan-steamer of IM25 is similar to those from LBM1:11 of Bianjiazhuang, Longxian (The Baoji Work Center of the Shaanxi Institute of Archaeology 1988) and M1:5 of Fulinbao, Baoji, but the walls of the top part is slanting, which is more similar to that from LBM1:11 of Bianjiazhuang; the date of this yan-steamer would be between the two from Bianjiazhuang and Fulinbao. Seen from the potteries in the grave goods, the pottery dou-stemmed bowls have deeper bowl and thicker stem; the bodies of jars with trumpet-shaped rim were becoming smaller and the shoulders were changing from bending shoulders to round shoulders. All of the typological changes implied that the date of IM25 would be in the middle Spring-and-Autumn Period.

All of the bronzes in the grave goods of IIM1 are plain without any decorations; the yan-steamer is similar to that unearthed from BM27 of Baqitun Eastern Zhou tombs in Fengxiang, but the mouth is obviously larger. The bellies of the ding-tripods are shallow and the bottoms are flat, and the legs are made into the shape of hoof. Their casting technique is rather coarse, showing that they are made as funeral objects, and the styles are that of late Spring-and-Autumn Period. Therefore, the date of IIM1 would be in the late Spring-and-Autumn Period.

The size of IM25 is larger than that of IIM1, but both are accompanied with three ding-tripods, one yan-steamer and one sword (dagger), reflecting the similar statuses of the occupants of these two tombs. However, differences in grave good assemblages are also seen in these two tombs: a yu-vessel is seen in the bronze assemblage of IM25, plus large amounts of jade and stone objects, especially over 120 pieces of stone gui-scepters. Generally, being accompanied with chariots in the grave implies a higher status of the tomb occupant; for example, the Tomb No. 5 of the Spring-and-Autumn Period in Bianjiazhuang, Longxian, Shaanxi, whose occupant was an high-ranked official with Dafu status who had the authority to be accompanied with five ding-tripods and four gui-tureens. However, the occupant of IIM1 of Dapuzishan Site is accompanied with only three ding-tripods but also enjoyed a chariot, which is a phenomenon waiting for further exploration.

IM25 is the largest one in the medium- and small-sized tombs of Dapuzishan Site, and even larger than

the noble tombs of the Spring-and-Autumn Period in Yuandingshan Cemetery, Lixian County (The Institute of Archaeology of Gansu Province and the Lixian Museum 2002 and 2005). However, many tombs of Yuandingshan Cemetery were that of high-ranked aristocrats with Dafu or higher positions accompanied with seven or five ding-tripods, and usually accompanied with human victims, but the medium- and small-sized tombs around the Qin Duke Cemetery almost have no human victims yielded, and the bronze assemblages in the grave goods also implied the lower statuses of the tomb occupants, which is a considerable issue.

References

- The Baoji Work Center of the Shaanxi Institute of Archaeology 陕西省考古研究所宝鸡工作站 and the Archaeological Team of the City of Baoji 宝鸡市考古工作队. 1988. *Shaanxi Longxian Bianjiazhuang Wu Hao Chunqiu Mu Fajue Jianbao* 陕西陇县边家庄五号春秋墓发掘简报 (Excavation of the Spring and Autumn Period Tomb No. 5 at Bianjiazhuang in Longxian, Shaanxi Province). *Wenwu* 文物 (Cultural Relics) 11: 14–23.
- The Institute of Archaeology of Gansu Province 甘肃省考古研究所 and the Lixian Museum 礼县博物馆. 2002. *Lixian Yuandingshan Chunqiu Qin Mu* 礼县圆顶山春秋秦墓 (Excavation of Some Qin Tombs of the Spring and Autumn Period at Yuandingshan). *Wenwu* 2: 4–30.
- The Institute of Archaeology of Gansu Province 甘肃省考古研究所 and the Lixian Museum 礼县博物馆. 2005. *Gansu Lixian Yuandingshan 98LDM2, 2000LDM4 Chunqiu Qin Mu* 甘肃礼县圆顶山 98LDM2, 2000LDM4 春秋秦墓 (Excavation of the Qin Tombs of the Spring and Autumn Period at Yuandingshan, Lixian, Gansu). *Wenwu* 2: 4–27.
- The Paochi Archaeological Team, Institute of Archaeology, *Academia Sinica* 中国科学院考古研究所宝鸡发掘队. 1963. *Shaanxi Baoji Fulinbao Dongzhou Muzang Fajue Ji* 陕西宝鸡福临堡东周墓葬发掘记 (Excavations of Early Eastern Zhou Tombs at Fu Lin Pao Village, City of Paochi, Shensi). *Kaogu* 考古 (Archaeology) 10: 536–43.
- Yongcheng Archaeological Team, Shaanxi Province 陕西省雍城考古工作队. 1980. *Shaanxi Fengxiang Baqitun Qingguo Muzang Fajue Jianbao* 陕西凤翔八旗屯秦国墓葬发掘简报 (Excavation to the Tombs of the Qin State in Baqitun, Fengxiang County, Shaanxi). *Wenwu Ziliao Congkan* 文物资料丛刊 (Collected Writings on Cultural Relics Material) 3: 67–85.

Postscript: The original report was published in *Wenwu* 文物 (Cultural Relics) 2008.11: 30–49 with 46 illustrations, 33 of which are photographs. The original report and the abridged version are written by Hou Hongwei 侯红伟 and translated into English by Ding Xiaolei 丁晓雷.