

Excavation of a Large-sized Shang Tomb at Locus West of Xiaotun within the Yin Ruins in Anyang City, Henan

Anyang Archaeological Team, Institute of Archaeology, Chinese Academy of Social Sciences

Key words: *Yinxu* *Locus West of Xiaotun* *Tombs–Shang Dynasty*

In the winter of 2003 and the spring of 2004, in conjunction with the process of remodeling the north building of the Anyang workstation, our team conducted an excavation at Locus West of Xiaotun. 31 Shang tombs were excavated altogether, along with more than 10 storage and refuse pits, one sacrificial pit and two wells. In addition, more than 10 rammed-earth building foundations were uncovered. This report deals with a single large-sized tomb with two ramp passageways (2003AXTT2M1, hereafter abbreviated as M1).

The mouth of tomb M1 lies just beneath a layer of tilled earth. Shang-era remains related to M1 included 3 house foundations (F3, F4, and F7); 9 tombs (M14, M16–23); and one ash pit (H9). Among these, F3 was superimposed over M1, while F7, M14, and M16 intruded the north passageway of M1. The south side of M1 intruded Shang dynasty tombs M17–23 as well as H9; both F3 and the east wall of M1 intruded F4.

This large tomb had been looted more than 20 times, and the majority of the looting tunnels contained large accumulations of red burnt earth chunks from the collapsed buildings. There were fragments of wattle-and-daub walls built with bundles of reeds; chunks of rammed earth with ramming marks; remnants of roofs; large amounts of whitewash from walls, etc., all the remains of Shang-era buildings. We surmise that these materials may have been rubbles from a building constructed atop M1 or a building of later date than M1. The tomb chamber had been severely looted. The four walls of the outer coffin chamber were still well preserved, though nothing remained of the inner coffin. Hardly anything remained of the grave goods, most of them having already been disturbed.

I. The Shape of the Tomb

M1 is a large Φ -shaped tomb with two ramp passageways extending from the north and south sides of the tomb chamber (Figures 1 and 2).

1. The North and South Passageways. Neither the north nor the south passageway has yet been completely cleared. The south passageway was placed in the eastern part of the south wall. Its shape was quite unusual, proceeding eastward first, then turning to the south. The eastward-reaching portion was 4.7m long and 3m wide, while the southward-reaching portion was 18.3m long, 16.3m of which has been excavated. As the east wall of the passageway had collapsed, and the west wall was incompletely constructed; thus the opening of the south passageway was irregular, measuring about 2m wide at the bottom. At a point about 10.5m along the north-south length of the west side of the ramp, a rectangular terrace had been constructed, measuring 2m long from north to south, 1.9m long from east to west; and about 1.8m below the original ground level. Likewise, at a point about 12m southward along the east side of the ramp, an oval pit had been scooped out to the east, reaching approximately 0.35m deeper than the floor of the passageway. The fill of the terrace and the oval pit was the same as that within the passageway, with the exception of a few potsherds and animal bones.

The south passageway sloped slightly from south to north, while the western extremity of the westward-turning portion was nearly level with the floor of the tomb chamber. The floor of the ramp was smooth and bore traces of foot traffic. Two smooth grooves, 10cm wide and ranging from 0.3–0.7cm deep, were found placed 1.3m apart in the middle of the ramp floor; these may

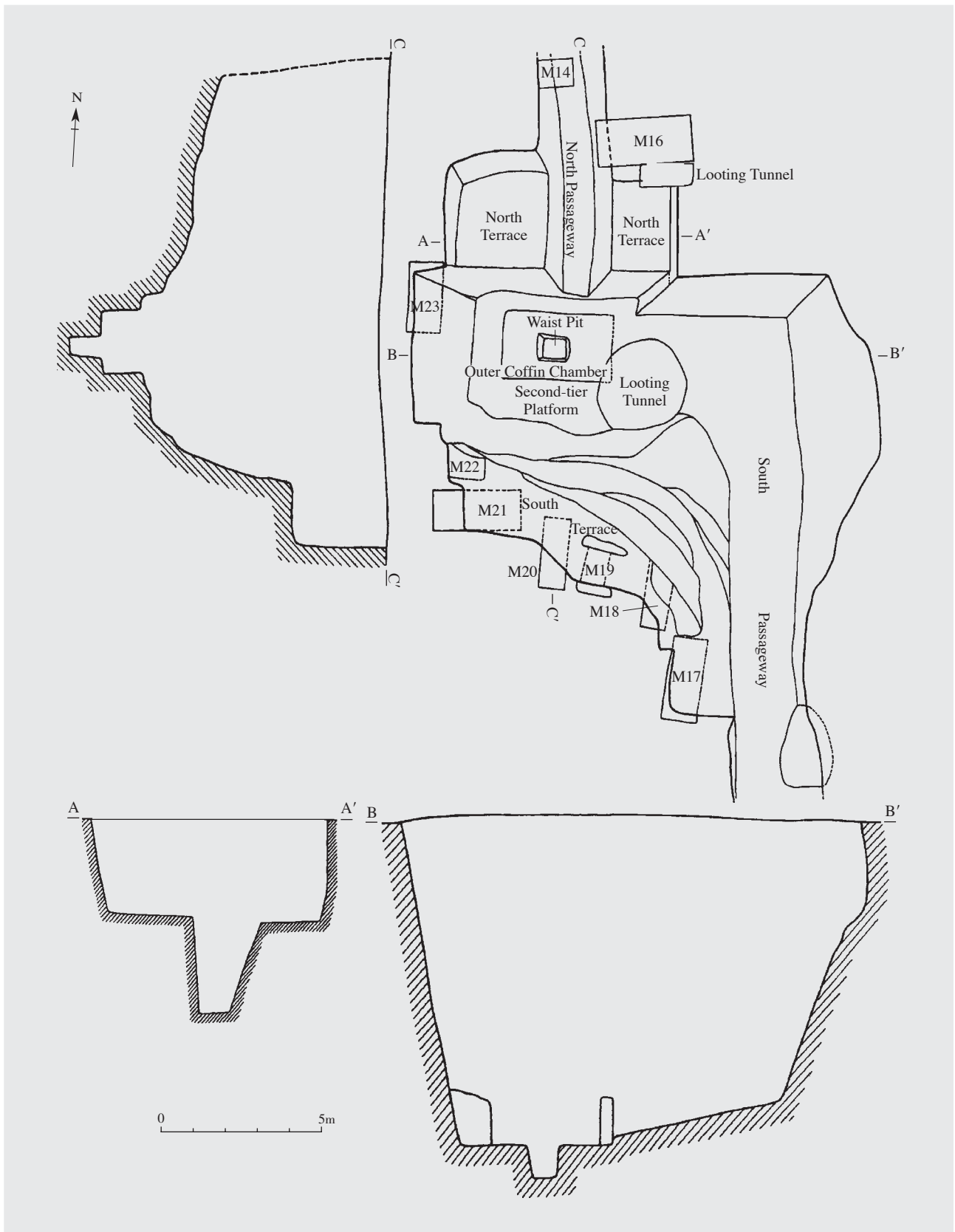

Figure 1. Plan and Cross-section of Tomb M1



Figure 2. The Full-view of M1 (E-W)

have been related to the construction of the tomb chamber or the transportation of the coffins and grave goods. Most of the fill in the south passageway was composed of mottled, yellow rammed earth, but the central section drew on grey rammed earth from some other location; it contained substantial amounts of potsherds, bone materials and animal bones.

The north passageway was at least 15m long; only 7m of that length were excavated. The mouth of the ramp was 2.1m wide, while the bottom ranged from 0.8–1m wide. The south end of the north passageway was 0.65m higher than the northern second-tier of the burial chamber and 2.15m higher than the floor of the chamber itself.

2. The Burial Chamber. The burial chamber was in a rectangular plan extending from east to west. The north and west walls were regular, as well as the baseline of the east wall; during the construction of the tomb, the opening had at some time caved in and had not been repaired, so that it formed an irregular arc. The south wall had not been completed and thus formed an extremely irregular slope bearing numerous tool marks. The north and west walls were smooth, their surfaces bearing a layer of fine yellow earth about 1cm thick; this seems to have been a layer of yellow mud applied as decoration or to reinforce the tomb walls.

The tomb opening was 8m long along the north wall, 4.8m along the west wall, and approximately 9m along the south wall, while the eastern side of the opening only extended 0.58m southwards from the north wall. The floor of the tomb measured 5.1m long along the north

wall, 3.6m along the west wall, and 7.4m along the south wall. The tomb was 10.5m deep. The four sides of the tomb chamber bore second-tier terraces of solidly rammed earth. The northern portion of the terrace was 0.5m wide; the western, 1m wide; and the southern, ranging from 1.3–1.8m wide; the terrace was 1.5m tall.

The tomb contained both inner and outer coffins. The cover of the outer coffin was composed of 11 long wooden planks ranging from 0.22–0.36m in width, while each of the four walls consisted of 6 planks stacked atop each other. The outer coffin was 3.4m long, 2.1m wide, and 1.5m deep. The planks were not carefully

processed. They seem to have been round logs split vertically and then directly employed, with the flat surface facing either upwards or inwards; patterns from tree bark and wood grain are clearly visible in the impressions they left behind. Bone nails measuring 11–15cm long were often seen in the plank impressions; these may have been used to reinforce the structure of the outer coffin in a manner similar to the use of nails in the inner coffin. Nothing remained of the inner coffin itself due to the severe disturbance wrought by the looting of the tomb; the impressions it left behind were unclear.

A rectangular waist pit was found in the middle of the tomb chamber floor. The aperture measured 1m long (east-west) and 0.9m wide (north-south); the bottom measured 0.7m long (east-west) and 0.6m wide (north-south). The waist pit was 1m deep and was completely filled with silt.

3. The Terraces on the North and South Sides of the Tomb Chamber. Terraces were located to the left and right sides of the north passageway, 1.9m below the tomb opening. The opening of the western terrace measured 3.1m on the west side and 2.6m on the north, while the base measured 2.5m along the west side, 2.7m along the north, 3m along the east, and 2.7m along the south. The opening of the east terrace was broken by a looting tunnel; it measured 2.1m along the north side, 3m along the east, and 2m along the south, while the base measured 1.8m east to west and 2.9m north to south.

There was a terrace along the south side of the tomb chamber as well, corresponding for the most part with

that on the north side; its shape was irregular due to the caving in of a portion of the wall of the south passageway. It measured approximately 6m wide (east-west) and 1.7–2.8m wide (north-south); it reached a depth of 2.1m from the mouth of the tomb. Judging from the clear traces of footprints on both the north and south terraces, these may have been used as excavation stages during the construction of the tomb.

II. Accompanying Human and Animal Burials

1. Accompanying Human Burials. A total of eight people accompanied the occupant in the tomb; some were placed on the north and south second-tier terraces of the tomb chamber, while others were located within the outer coffin chamber (Figures 3 and 4). The south terrace bore two human skeletons in extended supine position. The skeletons were preserved well; based on the teeth, both appear to have been young males at 14 to 15 years of age, wearing fur costume. Two human skeletons were placed on the north second-tier terrace as well; these had been disturbed by looting, the skull of one of which was found in the looting tunnel.

Five skulls were found within the outer coffin chamber, as well as a number of scattered limb bones, all having been badly disturbed by looting. One of these skulls presumably belonged to the tomb occupant; the other four were likely the accompaniments.

2. Accompanying Animal Burials. There were a total of six dogs buried in the tomb. One of these was found in the tomb fill at a distance of

about 0.6m above the planks covering the outer coffin; since the outer coffin chamber had caved in, the skeleton was scattered. Two were located on the west second-tier terrace of the tomb chamber, both with their heads toward the north and facing west; each also wore a bronze bell on the neck. Three were in the fill of the second-tier terrace. The fill of the north second-tier terrace contained two, spaced 1.3m apart, with their heads toward the west; the remaining dog was found in fill of the south second-tier terrace, with its head also oriented westward.

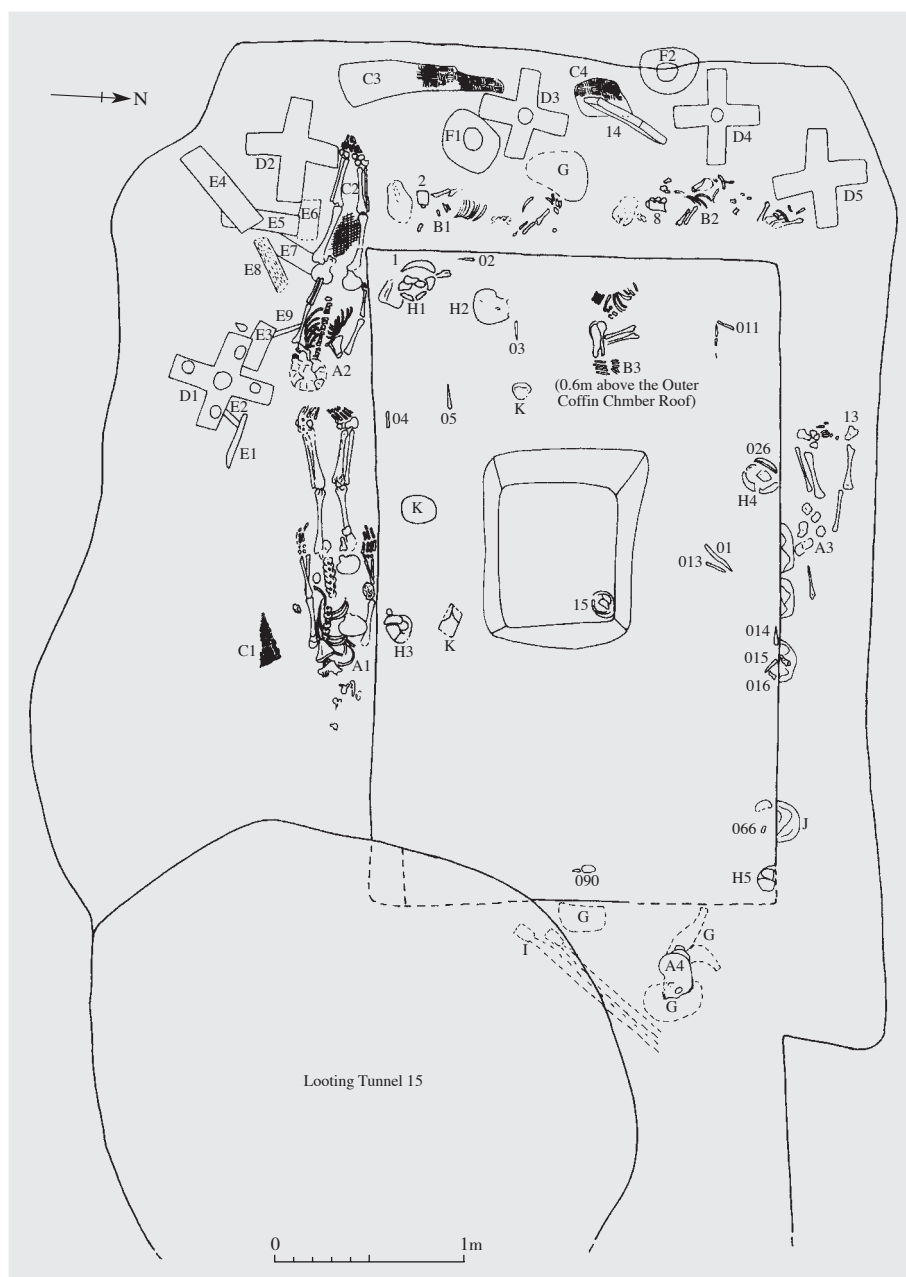

Figure 3. The Plan of M1



Figure 4. The Skeletons of the Accompanying Human Victims on the South Second-tier Terrace of M1 (E-W)

III. Grave Goods

The tomb contained a total of over 140 items of grave goods. Due to the extensive looting, very few grave goods remained in the outer coffin chamber, and most of these were no longer in their original positions. The remaining items were for the most part found on the south and west second-tier terraces. One music stone was found built vertically in the rammed earth. Five cruciform frame bases were found as well. Two of these were located to the sides of the music stone, their center points were about 1m apart from each other. Each cruciform frame base bore a round hole approximately 8cm in diameter at its center, probably intended to be used to fix a pillar of the music stone frame. These frame bases were probably used as the bases of music stone frame (Figures 5 and 6). Traces of lacquered leather object in oval shape were found on the two sides of either of the two cruciform frame bases; these may have been ornamentation for the music stone frame. Two of the remaining cross-shaped frames were placed at the northwest and southwest corners of the second-tier terrace, which may have belonged to a music stone frame but were placed in different locations. The remaining frame base, located on the eastern part of the south second-tier terrace, was unusual in form. Besides of the round pillar in its center, a number of small black-lacquered sticks were placed horizontally to its side. It is not known whether these were components of the frame

base itself or drumsticks (Figure 7). This frame base may have been that of a drum stand; though nearly half of the drum itself was destroyed by the looting tunnel, it is possible to discern the basic form of a Shang drum from the remaining portion. Two square-headed lacquer staffs, one stone implement, and a number of fragments of lacquer wares were recovered from the fill of the east second-tier terrace.

The artifacts discovered included potteries, bronzes, lacquer wares, jade and stone items, bone items, ivory, shell implements, etc. Most of these were recovered from the looting tunnels; very few remained undisturbed (a “0” has been added to the beginning of the item num-

bers of those ones that had been disturbed prior to excavation).

1. Potteries: A total of 6 pieces, including a *guan-jar*, lids, etc.

One *guan-jar* (M1:15) was excavated from the waist pit. It is made of grey fine pottery, with a flared lip, a contracted neck, slanting shoulders, and a belly protruding at upper part and shrinking inward at lower part.

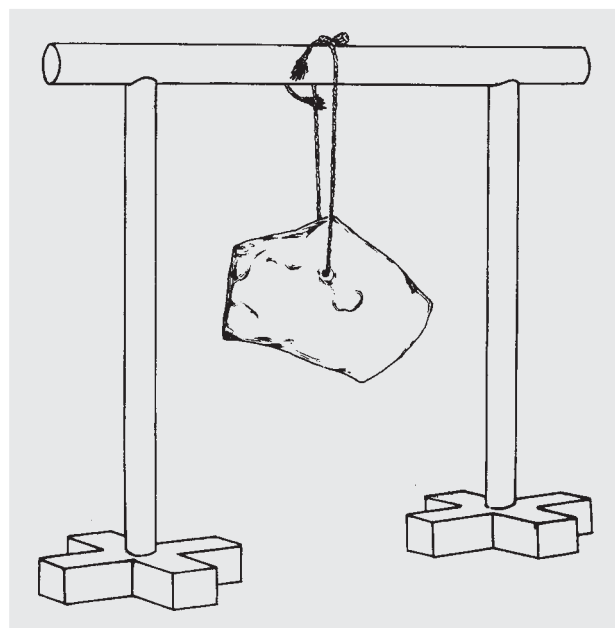

Figure 5. The Imaginary Restoration of the Suspending Type of the Music Stone on the West Second-tier Terrace

The bottom is slightly concave, and the shoulders bear symmetrical solid horizontal lugs. The neck and shoulder are decorated with concave bowstring lines, while the belly portion bears incised triangle patterns. The mouth is 8.4cm in diameter (Figure 8:1).

Two lids were found, both of which are made of orange-red fine pottery. M1:091 is in the shape of a pointed rain-hat with a round rim. It is 22cm in diameter and 6.4cm tall (Figure 8:2).

2. Bronze items. A total of 33 bronze items were found, including small bells, arrowheads, etc.

Two small bells were recovered from the neck of the dogs on the west second-tier terrace. M1:2 is oval in its horizontal cross-section; it has a flat mouth, a bridge-shaped protrusion, and a “U”-shaped stud suspended in the inside portion. The body of the bell bears inverted animal mask design. The mouth of the bell is 5.5cm long and 3.6cm wide at its widest point; the entire bell is 8.7cm tall (Figure 10:1).

25 arrowheads were found, all triangular in shape. M1:031 is 7.2cm long (Figure 10:2).

3. Lacquer Items. In addition to the cruciform music stone and bell frame bases and the square-headed lacquer staffs, a number of lacquer items were found in the disturbed soil of the outer coffin chamber. The original shapes of many of these items could not be assessed; among those that could be identified were a square lacquer tray and a *dou*-stemmed bowl.

4. Jade items. 8 jade items were found in all, including *ge*-dagger axes, a spearhead, a tiger, etc.

Two jade *ge*-dagger axes were found. M1:035 is grayish-white in color. The point has been broken off; the cross-section forms a rhombus. The item has a straight tang, and the area where the tang and the blade join bears a small round hole. The remaining portion of the blade is 3cm wide and 11.2cm long (Figure 10:4).



Figure 6. The Cruciform Base of Music Stone Frame from M1 in situ (E-W)



Figure 7. The Cruciform Base of Music Stone Frame and Black-Lacquered Sticks from M1 in situ (N-S)

One jade spearhead (M1:038) was found, greenish-gray in color, partially damaged. It is 6.8cm long (Figure 10:5).

One jade tiger (M1:037) was found, green in color, missing its tail; the remaining portion is 6.5cm long (Figure 10:3).

5. Stone implements. Six stone implements were found in all, including a music stone, a whetstone, etc.

One music stone (1:14) was recovered. One end of the item has been broken off. The remainder is smoothly polished; a round hole is biconically drilled through the upper central portion. The stone is 36.6cm long along the base and 35cm tall (Figure 9).

One whetstone (M1:042) was found, strip-shaped,

with one end broken off; a round hole uniconically drilled remains in the broken surface. The remainder of the item is 8.2cm long (Figure 10:6).

6. Bone items. 42 bone items were found, including awl-shaped objects, bow-caps, etc.

14 awl-shaped bone objects were found, crudely made and generally similar in shape. 9 of these awl-like items were found undisturbed, having been driven into small cracks in the boards making up the four walls of the outer coffin chamber; these were probably used as nails to stabilize the outer coffin. M1:9 is 13.8cm long (Figure 10:7).

10 bone bow-caps were found. Five of these bear U-shaped prongs at the top. M1:045 has a contracted waist;

it is 4.5cm long (Figure 10:8). Five instead have round holes bored into their tops. M1:049 is 4.9cm long; the hole in its top is 0.6cm in diameter (Figure 10:9).

7. Ivory/tusk items. 39 items of ivory and tusk were found; those of which the original shapes can be determined include *Xi* 觥-bodkin, ornaments, etc.

One fish-shaped ivory *xi*-bodkin was recovered (M1:1). It bears finely carved line décor, with turquoise inlaid at many spots. It is 15.7cm long (Figure 11).

36 decorative items of ivory or tusk were found. These were generally similar in shape, all forming rectangular plates with two round holes bored into each of the two shorter sides. This type of decorative item is often seen in Shang Dynasty horse and chariot pits; it was probably used as an ornament for horses. M1:070 is 2.7cm long and 1.8cm wide.

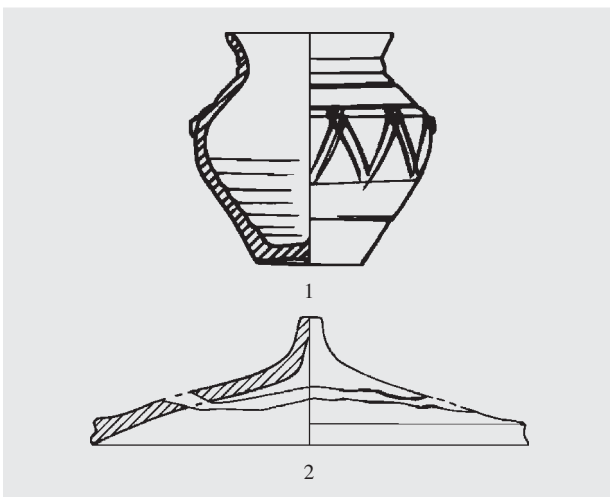

Figure 8. Potteries from M1
1. pottery guan-jar (M1:15) 2. pottery lid (M1:091)

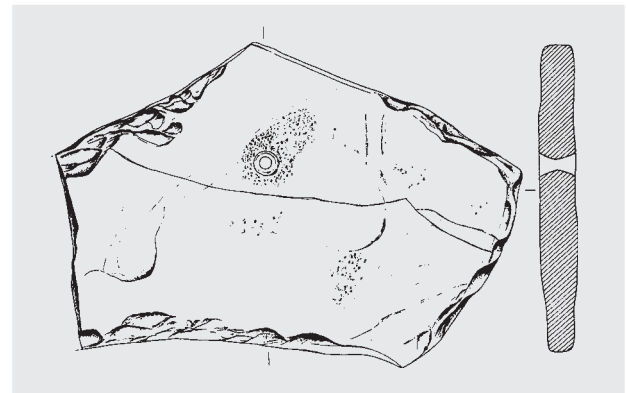

Figure 9. Music Stone (M1:14)

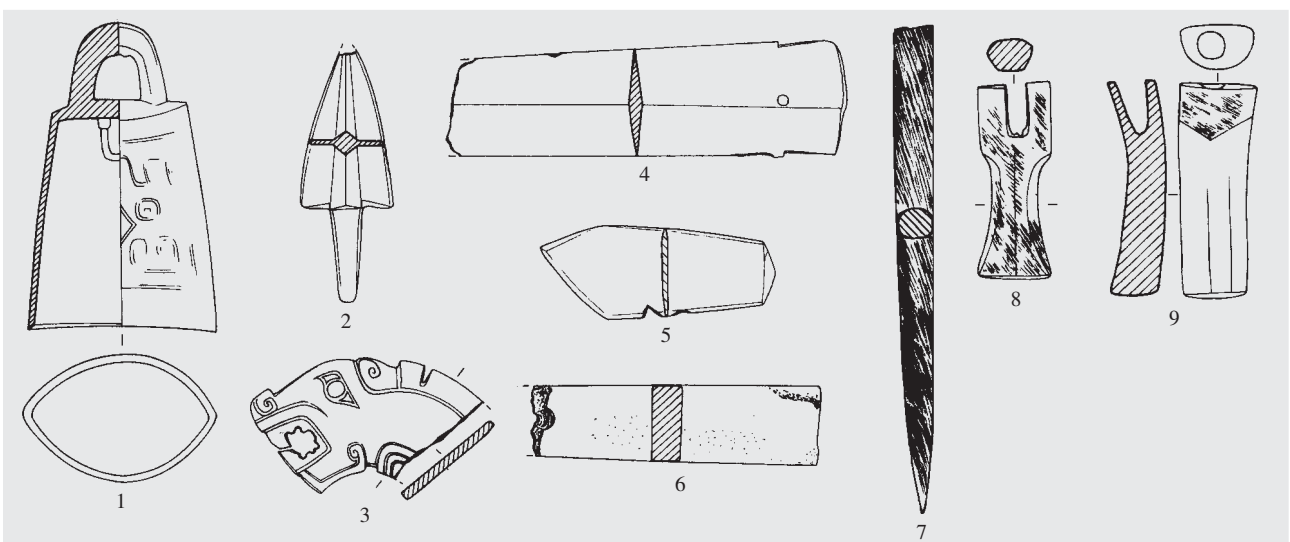

Figure 10. Miscellany from M1
1. bronze bell (M1:2) 2. bronze arrowhead (M1:031) 3. jade tiger (M1:037) 4. jade ge-dagger ax (M1:035) 5. jade spearhead (M1:038) 6. whetstone (M1:042) 7. bone awl-shaped object (M1:9) 8 and 9. bone bow caps (M1:045 and M1:049)



Figure 11. Ivory Fish-shaped Xi-bodkin (M1:1)

8. Shell implements. Five shell items were found, including clam shells, shell ornaments and cowries.

A few additional items were recovered from the soil filling the tomb, including pottery balls, bronze awls, bone awls, bone materials, etc.

IV. Conclusions

1. The position and shape of the tomb. The location of tomb M1 is worthy of emphasis. Of the 15 tombs with two passageways discovered at Yinxu to date, only this tomb was located near the palace and ancestral temple zones at Xiaotun; this point is of greater than usual significance.

The shape of M1 is unusual as well, in that the tomb chamber is oriented east-west; the south passageway proceeds first eastward before turning southward; and terraces were found both on the south side of the tomb chamber and to the east and west sides of the north passageway where it let out into the tomb chamber. This sort of tomb shape is exceedingly rare at Yinxu.

2. The date of the tomb. Stratigraphic evidence and

the artifacts recovered provide a basis for analyzing the date of tomb M1. Tombs M14 and M16, both of which intruded M1, contained grave goods. The pottery *li*-cauldron recovered from M14 and the pottery *gu*-goblet and *jue*-cup recovered from M16 are all of types commonly seen in remains belonging to Yinxu Phase IV; thus, the relative dating of M1 should be no later than Phase IV. The pottery *guan*-jar recovered from the waist pit of M1 (M1:15) is essentially identical to a *guan*-jar excavated from tomb M1046 (M1046:57), discovered in Locus North Liujiazhuang. In addition, the two pottery lids in the shape of rain-hats recovered from a looting tunnel in the outer coffin chamber of M1 are of the same shape as three similar items (H137:4, 5 and 15) excavated from refuse pit H137 at Xiaotun in 1985. M1046 and H137 are both typical remains of the late stage of Yinxu Phase IV. Accordingly, the date of interment of tomb M1 should also fall in the late stage of Yinxu Phase IV.

3. Status of the tomb occupant. The severe looting that M1 underwent left behind no materials for determining the status of the tomb occupant. However, based on the relatively large size of the tomb, its two passageways, and its position near the palace and ancestral temple zones of Xiaotun, M1 was probably built to a higher standard than that of Fu Hao's tomb; accordingly, its occupant must have been a high-ranking Shang aristocrat or a member of the royal family. Moreover, M1 belonged to the late stage of Yinxu Phase IV; considering its date as well as the fact that the tomb was hurriedly closed before it was completed, M1 is an unusual specimen indeed.

References

- The Anyang Archaeological Team, Institute of Archaeology, Chinese Academy of Social Sciences 中国社会科学院考古研究所安阳工作队. 2004. *Anyang Yinxu Liujiazhuang Bei 1046 Hao Mu* 安阳殷墟刘家庄北 1046 号墓 (Tomb 1046 to the North of Liujiazhuang at the Yinxu Site in Anyang). *Kaoguxue Jikan* 考古学集刊 (Papers on Chinese Archaeology) 15: 359–90; especially Figure 4:6 on p. 363.
- Institute of Archaeology, Chinese Academy of Social Sciences 中国社会科学院考古研究所. 2004. *Anyang Xiaotun* 安阳小屯. Beijing: Shijie Tushu Chubanshe. Figure 61 on p. 125.

Postscript: The original report was published in *Kaogu* 考古 (Archaeology) 2009.9: 54–69, with 16 illustrations and 3 plates comprising 7 images. The present version is written and revised by Yue Zhanwei 岳占伟 and Yue Hongbin 岳洪彬 and translated into English by Nicolas Vogt 侯昱文.