

Excavation of Tomb M28 in the Cemetery of the Rui State at Liangdai Village in Hancheng City, Shaanxi

Shaanxi Provincial Institute of Archaeology

Key words: The Rui State (in the Spring-and-Autumn Period) Royal Tombs Spring-and-Autumn Period

The Cemetery of the Rui State is located to the north of Liangdai Village in Zancun Township, Hancheng City, Shaanxi Province, 0.5km to the west of the Yellow River, 10 km to the northeast of Hancheng City seat, and 8 km to the south of Zancun Township; the Xi'an-Yumenkou Expressway cuts through the western part of the cemetery. In 2005 and 2006, the Shaanxi Provincial Institute of Archaeology excavated three large-sized tombs with ramp passageways. Inscriptions of bronze vessels from these tombs indicated that the occupants were the monarchs and their spouses of the Rui State. To deepen our knowledge to the Cemetery of the Rui State, we excavated M28, M502 and other tombs in 2007. Below are the results of the excavation of Tomb M28.

I. The Location of Tomb M28 and Its Structure

Tomb M28, a large rectangular tomb with one ramp passageway, is located in the southeast of the southern zone of the cemetery, 27m to the southeast of M27, the tomb of Lord of Rui (Figure 1). Rectangular in shape, the tomb is 5.4–5.5m long and 4m wide at the ground, 5m long and 3.5m wide at the bottom, and 9.4m deep. The space between the chamber and walls is filled with used earth of 0.25–0.3m wide and 1.8m high. Oriented 196°, the ramp is set to the south of the shaft pit with a length of 19m. The shaft pit and ramp, 22m long altogether, are filled with layers of brownish yellow rammed earth of 0.1–0.3m thick (Figures 2 and 3).

II. Tomb Furniture and Burial Positions

The furniture of Tomb M28 consists of one coffin chamber and two layers of coffins, all of which are rotten at the time of excavation. The roof of the chamber is com-

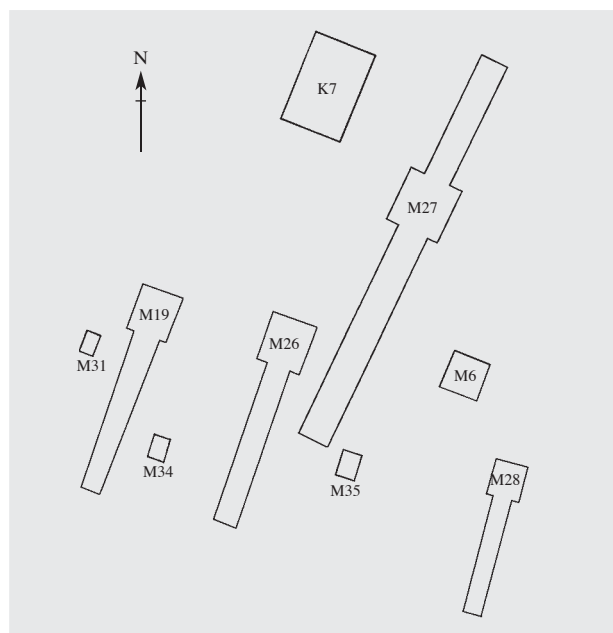

Figure 1. The Location of M28 in the Cemetery of the Rui State

posed of fourteen planks of 0.16–0.26m wide and 5cm thick (Figure 4). The bottom is composed of fifteen wedge-shaped planks of 4.63m long, 0.18–0.23m wide and 4–8cm thick. The eastern and western walls are comprised of seven planks of 4.7m long, 0.16–0.35m wide, and 1.6m high altogether (originally 1.75 m, sank for 0.15–0.2 m); the northern and southern walls are comprised of eight planks of 3.01m long, 0.16–0.27m wide, and 0.09m thick. At the northern and southern ends of the bottom of the chamber, there are two traverse square logs of 3.5m long, 0.24–0.25m wide, and 0.08m thick. The chamber itself is 3.16m wide, 4.65m long and 1.8m high. Upon the roof are laid a line of pairs of bronze fittings (Figure 5).

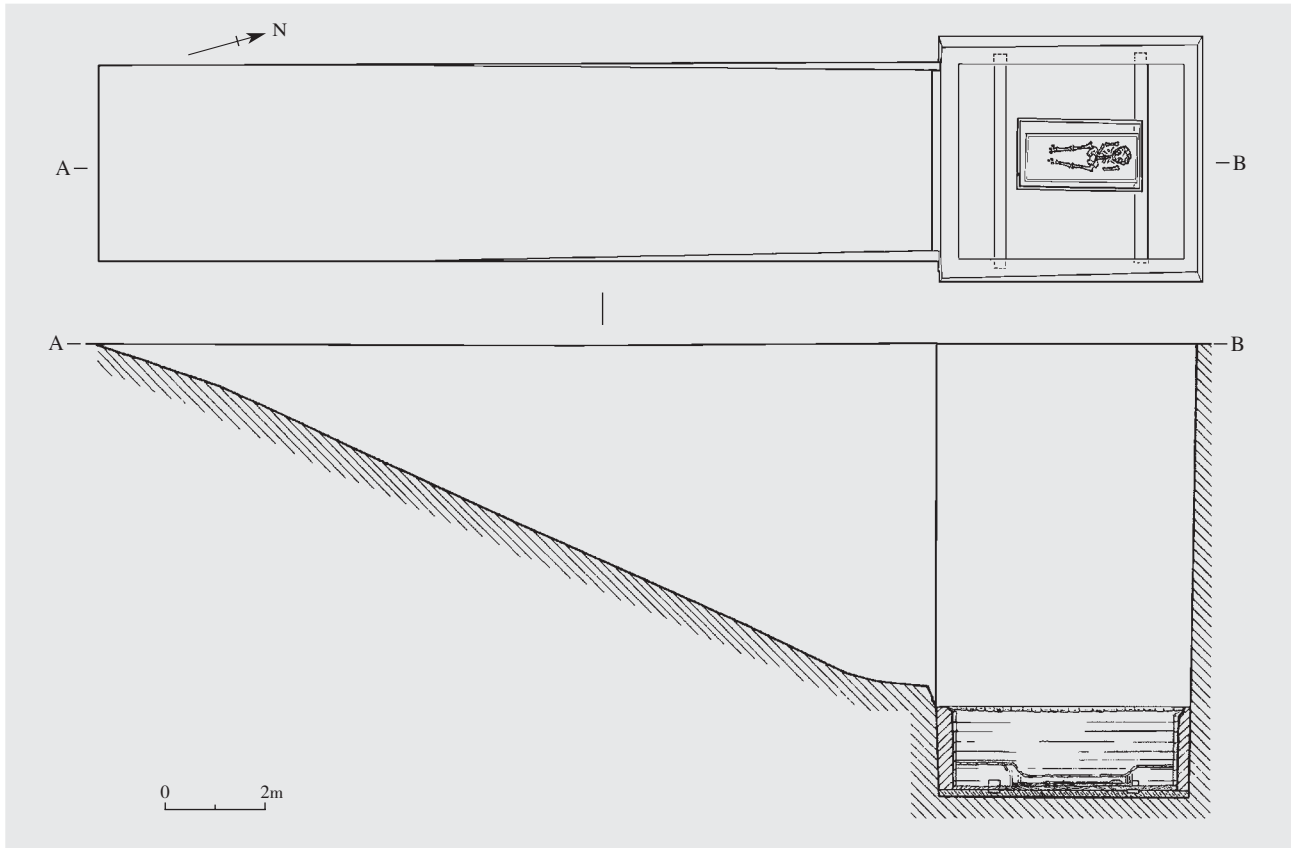

Figure 2. The Plan and Side Section of M28

The coffins are placed in the middle-towards-west of the chamber. Their charred remains indicate that they are both rectangular. The outer coffin is 2.6m long and 1.16m wide, the inner coffin 2.34m long and 0.8m wide; they are 0.05–0.10m apart. Both are collapsed, and their remaining heights are 0.4m. The thickness of the coffin planks is 4–5cm.

At the time of excavation, bronze fishes and stone pendants, which are scattered around the outer coffin, seem to constitute the shape of 目. Around the outer coffin are also found bronze fishes painted with red and black pigments, which might have been ornaments of the funeral palls over the outer coffin.

The skeleton of the occupant has already decomposed. Its trace suggests that the occupant was in extended su-



Figure 3. Full-view of M28 with the Grave Goods (Top is East)

pine position. It is a male and his teeth reveal that he died at around 50. His body is decorated with some circular and triangular belt ornaments only.



Figure 4. The Traces of the Roof Planks of the Coffin Chamber of M28 (Top is East)



Figure 5. The Distribution of the Bronze Disc-shaped and Fish-shaped Pall Ornaments (Top is East)

III. Grave Goods

Grave goods of Tomb M28 are placed upon mats woven with reed and bamboo between the coffins and the chamber. Among them bronze ritual vessels and stone ritual artifacts are placed in the southeastern and northwestern corners; weapons, chariot-and-horse fittings, and funeral ritual goods are scattered upon the coffins and the western, eastern and southern sides; lac-

quer wares are concentrated in the northeastern and northwestern corners, but a few of them are found in the southwestern corner (Figures 6–14).

1. Bronze artifacts, which are mainly of ritual vessels and musical instruments, weapons, chariot-and-horse fittings, and funeral ritual objects.

There are twenty-six ritual vessels. Among them five are *ding*-tripods, which have the same décor but graded sizes, with heights of 20.1–32cm (Figures 15:4 and 16). Four are *gui*-tureens, which have identical décor and size, with a height of 18.8cm (Figures 15:1 and 17). Five are *li*-cauldrons, which also have identical décor and size, with a height of 11.8cm (Figure 18). One is *he*-pitcher of 25.4cm high (Figures 15:2 and 19). Two are *hu*-pots, which have identical décor and size, with a height of 40cm (Figures 15:5 and 20). One is a pan of 34.8–36cm in diameter at rim and 13.8cm high (Figures 15:3 and 21), one is a *yan*-streamer of 33.6cm high (Figures 15:7 and 22). Eight are chime bells of identical form and décor but of varying sizes of 20–41.4cm high (Figures 15:6 and 23), eight bell hooks also of identical form and décor but of varying size of 6.5–10.5cm long (Figure 31).

Of weapons there are 28 items. Among them six are *ge*-dagger axes with long vertical blades and three

or four holes for fastening shafts (Figure 24:3); three are spearheads, which, 20.3–20.8cm long, retaining shaft traces (Figure 24:6). 19 are arrowheads, which occur in two types: A (17 pieces, Figure 24:5) and B (2 pieces, Figure 24:4). Over 90 are bronze armor plates, most of which are placed in the southeastern corner, but isolated pieces are also found in other places. They are mostly rectangular, 12.5–13cm long and 9cm wide, and weigh 36.9–40.2g (Figure 9).

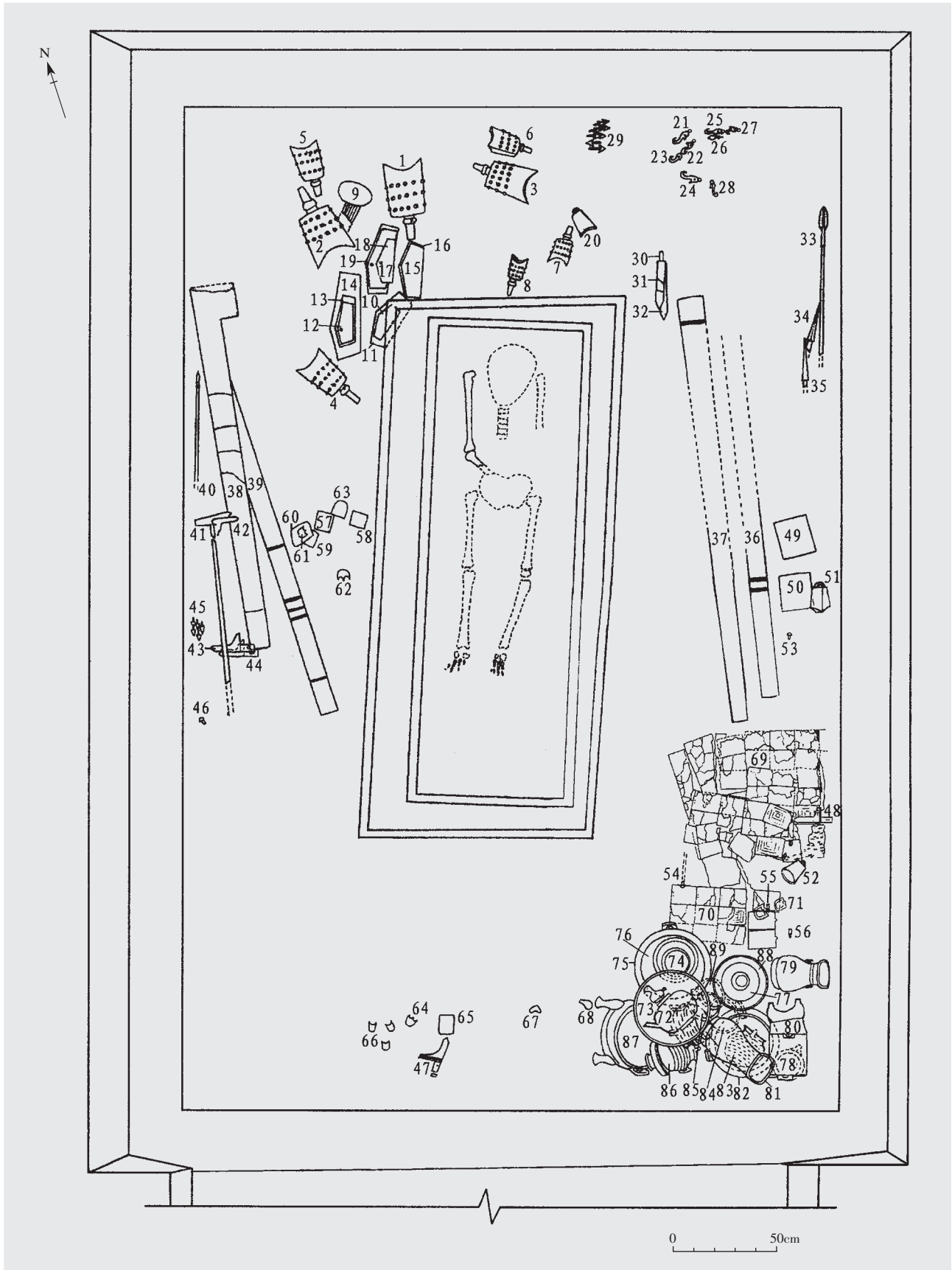

Figure 6. The Distribution of the Grave Goods (Bottom Layer)

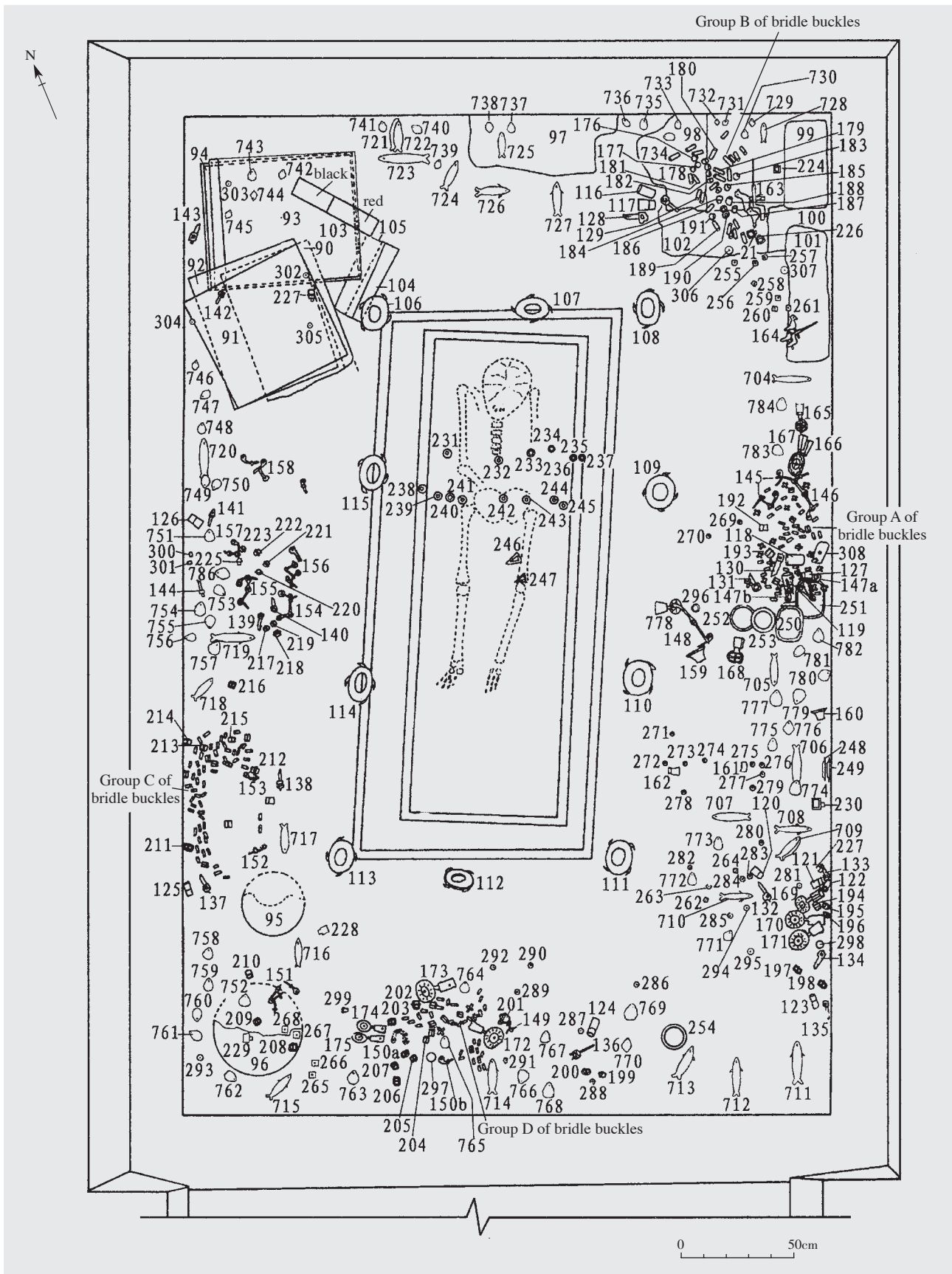

Figure 7. The Distribution of the Grave Goods (Top Layer)



Figure 8. The Bronze Ritual Vessels in situ (N-S)



Figure 9. The Bronze Armor Plates in situ (Top is North)



Figure 10. The Chariot and Horse Fittings in situ (N-S)



Figure 11. The Horse Armors and Bridle Fittings in situ (W-E)



Figure 12. The Musical Instruments and Lacquer Wares in situ (Top is West)



Figure 13. The Trace of the Lacquered Chime Bell or Chime Stone Frame (Top is West)

Figure 14. The Lacquer Wares in situ (Detail, Top is West)



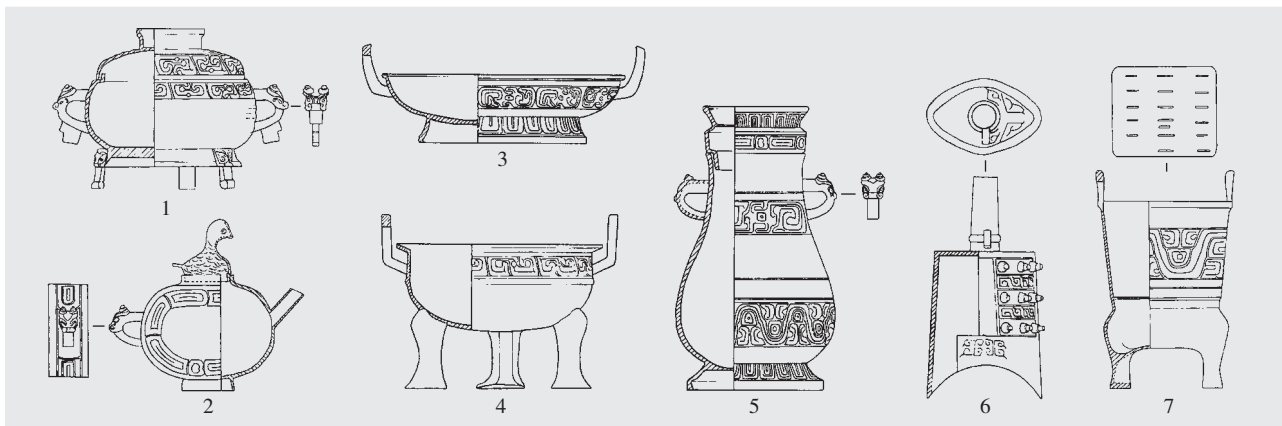

Figure 15. Bronze Ritual Vessels and Musical Instruments

1. gui-tureen (M28:83) 2. he-pitcher (M28:72) 3. pan (M28:73) 4. ding-tripod (M28:88) 5. hu-pot (M28:79); 6. chime bell (M28:4) 7. yan-steamer (M28:80)



Figure 16. Bronze Ding-tripod (M28:88)



Figure 17. Bronze Gui-tureen (M28:83)



Figure 18. Bronze Li-cauldron (M28:89)



Figure 19. Bronze He-pitcher (M28:72)



Figure 20. Bronze Hu-pot (M28:79)



Figure 21. Bronze pan (M28:73)



Figure 22. Bronze Yan-steamer (M28:80)



Figure 23. Bronze Chime Bell (M28:4)

Of chariot and horse fittings there are over 170 items. Among them there are 12 axle caps (Figures 24:1 and 25) and 12 linchpins (Figure 24:8). There are two yoke top finials (Figures 24:12 and 26), two bird-shaped ornaments (Figure 27), 14 pairs of horse snaffles and bits of identical shape but varying sizes (Figures 11 and 24:2), twelve chariot bells also of identical shape but vary-

ing sizes (Figures 24:9 and 28), four yoke saddle end finials of identical shape (Figure 24:13). There are 401 bridle buckles of five types: 11 are cross-shaped, six are X-shaped, 218 are oval barrels (Figure 24:16), 179 are barrels (Figure 24:10) and six are double-barreled ones (Figure 24:14).

Of other bronze artifacts, there are 10 disc-shaped

ornaments of identical size and décor, equidistantly placed around the coffins (Figures 29 and 30). There are 16 beads (Figure 24:15), 318 bronze fishes of identical shape and varying sizes, nine circular belt ornaments with openwork intertwined serpent design, 43 oval bells with flat tops, semi-oval hanging rings and clappers inside, five hinges roughly of square shape with



Figure 24. Bronze Weapons and Chariot and Horse Fittings

1. axle cap (M28:121) 2. horse snaffle (M28:147-1) 3. ge-dagger-ax (M28:47) 4. arrowhead (Type B, M28:29-10) 5. arrowhead (Type A, M28:29-2) 6. spearhead (M28:33) 7. shaft finial (M28:55) 8. linchpin (M28:143) 9. chariot bell (M28:173) 10. bridle buckle (Type D, M28:B8) 11. horse bit (M28:147-2) 12. yoke top finial (M28:159) 13. yoke saddle end finial (M28:162) 14. bridle buckle (Type E, M28:C9) 15. bead (M28:176) 16. bridle buckle (Type C, M28:A5)



Figure 25. Bronze Axle Cap (M28:121)



Figure 26. Bronze Yoke Top Finial (M28:159)



Figure 27. Bronze Bird-shaped Yoke Ornament (M28:163)



Figure 28. Bronze Chariot Bell (M28:173)



Figure 29. Bronze Disc-shaped Pall Ornament (M28:112)

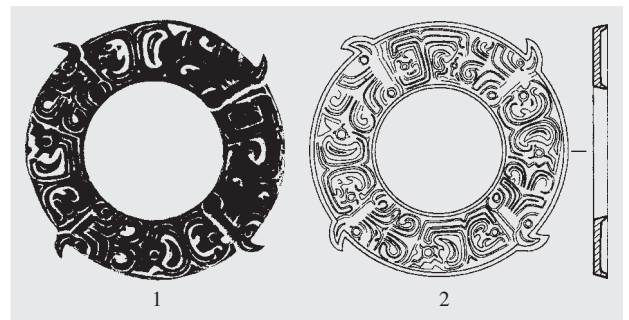

Figure 30. Bronze Disc-shaped Pall Ornament (M28:112)
1. Rubbing 2. Line Drawing

axles and axle holes and decorated with animal heads and phoenixes, two mushroom-shaped ornaments, 38 animal-head-shaped belt buckles of identical size, shape and décor, and four rings.

2. Of jade, stone, and bone artifacts, there are over 180 items. Among them there are 2 jade *gui*-scepters 23.7cm long (Figure 32:7), 10 chime stones in reducing

sizes, of which one is 29.2cm (Figure 32:9); 33 circular stone ornaments (Figure 32:5), 13 square stone ornaments (Figure 32:6), 789 stone pendants (Figures 32:1–3), one stone knife 9.5cm long (Figure 32:8) and seven circular bone ornaments (Figure 32:4).

3. Lacquer wares have all their bodies rotten; what is extant is lacquer coating only. Among those whose forms can be told, there are four plates of square form, 60–71cm long per side, four cases, four bell and chime stone stands with S-form scrolls, fish scale, and feather designs (Figures 13 and 14).

IV. Conclusion

The five *ding*-tripods from Tomb M28 are analogous to those found in Tombs M26 and M27 at the Cemetery of the Rui State and those found in tombs such as M93 of the Cemetery of the Jin Marquises in Quwo, but their hoof-shaped legs are more bending outward, which is a salient characteristic of the Spring-and-Autumn Period. The tomb therefore dates not only later than M93 of the Cemetery of the Jin Marquises, but also later than M26 and M27 at the Cemetery of the Rui State. The two bronze *hu*-pots have modest bellies and their lids are larger than their openings, which is far parted from the Western Zhou style and comparable with those from the Qin State tombs at Fulinbao of the Middle Spring-and-Autumn Period. Tomb M28 therefore dates later than M27 and roughly to the early Spring-Autumn Period.

Inscriptions from bronze ritual vessels of Tomb M27 indicate that the occupant is a monarch of the Rui State,

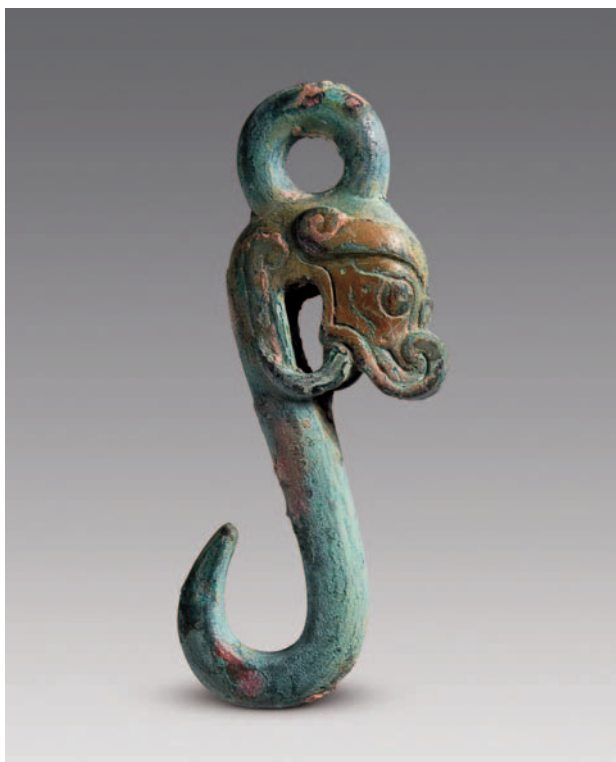

Figure 31. Bronze Bell Hook (M28:25)

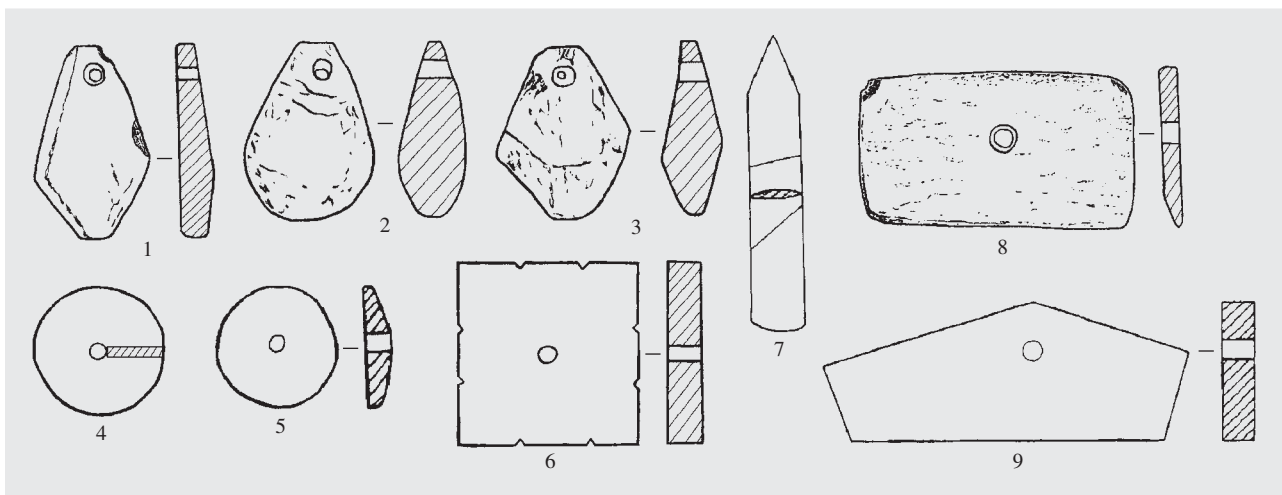

Figure 32. Jade and Stone Objects

1–3. stone pendants (M28:758, M28:779, M28:755) 4. bone ornament (M28:307) 5. circular stone ornament (M28:283) 6. square stone ornament (M28:266) 7. jade *gui*-scepter (M28:31) 8. stone knife (M28:308) 9. chime stone (M28:12)

whereas those of M26 and M19 are his wife Zhongjiang and his concubine. M28 is located to the lower right of M27, and its structure is similar to M19 and M26, but it is slightly farther away from them. The occupant of this tomb is a male, and he could not be another wife of the occupant of M27. Albeit M28 is smaller than M27, it yields five *ding*-tripods and four *gui*-tureens, eight chime bells, and 10 chime stones, the assemblage of which surpasses those of M19 and M26. At the Cemetery of the Jin Marquises, each Jin Marquis is accompanied with five *ding*-tripods and four *gui*-tureens, which appears to

be a regular ritual vessel assemblage of monarchs of the time. It is reasonable to suppose that the occupant of Tomb M28 was another, possibly the last, monarch of the Rui State.

Although Tomb M28 does not produce any inscribed ritual vessel, the ensemble of ritual vessels, weapons, chariot-and-horse fittings, ornaments, jade tablets, and funeral pall ornaments offers valuable insights into the funeral rites of the Zhou Dynasty at large and burial customs of the Rui State in particular.

Postscript: The original report was published in *Kaogu* 考古 (Archaeology) 2009.4: 3–15 with 10 illustrations and eight pages of plates. The authors and rewriters are Lü Zhirong 吕智荣 and Zhang Tian'en 张天恩 and the translator of the English version is Zhang Liangren 张良仁.