

# A Western Zhou tomb at Shigushan in Baoji, Shaanxi

## Shigushan Archaeological Team

### Abstract

The Shigushan Western Zhou tombs are located at Shizuitou Village in Shigu Town, Weibin District, Baoji City, Shaanxi Province. Tomb M3, excavated in 2012, was in the form of a vertical pit with a rectangular plan and artificial ledge. Recesses were found on the east, north, and west walls of the grave. The tomb furnishings consisted of an inner coffin and two outer coffin chambers. Grave goods unearthed from this tomb include bronze ritual vessels, weapons, and chariot fittings. Altogether, 31 pieces representing 14 types of bronzes have been excavated. The tomb is dated to the transitional era from the Late Shang to the Western Zhou Dynasties. Since the assemblages of bronzes, which are all exquisite pieces of art, include almost every major kind of bronzes, the occupant was probably a relatively high-status aristocrat. In addition, the excavation has provided essential new data for the study of Western Zhou bronzes and funeral customs and rites. This new discovery also has the potential to yield significant new insights and substantially improve the understandings of Western Zhou history, culture and ritual.

**Keywords:** Bronzes; burials—Western Zhou Dynasty; Jiang Rong (ancient ethnic group); Shigushan (Stone Drum Mountain, Baoji City, Shaanxi)

### Overview of the cemetery

On June 22nd, 2012, villagers from Shizuitou Village, Shigu Township, Weibin District, Baoji City, Shaanxi, discovered bronze items while digging a house foundation. The Shigushan Archaeology Team organized by the Shaanxi Provincial Institute of Archaeology, Baoji Municipal Institute of Archaeology and Weibin District Museum launched a rescue excavation.

Shigushan (lit. “Stone Drum Mountain”), where Shizuitou Village is located, is situated in

an elevated position surrounded by the Qinling Mountains to the south, the Wei River to the north, the Yinxiang River to the east and the Jujia River to the west (Figure 1). Since 2013, three Western Zhou burials (M1-M3) have been discovered successively. This report will introduce the excavation of M3 of them, as well as the general situation of the items recovered.

### The burial structure

Tomb M3 was a rectangular earthen pit shaft tomb with the orientation of 170°. It measured 4.3m long, 3.6m wide and 2.4m in remaining depth (Figures 2 and 3).

A rammed-earth ledge appeared on all four sides of the grave; it measured 0.8m wide on the north and south, 1m wide on the east and west, and 1.05m high. The grave goods placed on the ledge included weapons, horse and chariot fittings, etc. Recesses had been dug into the east, north, and west grave walls atop the ledge. The excavators numbered them as K1 to K6 in sequence from east to north to west (see Figures 2, 4 and 5). K1, located slightly north of the center of the east wall, was 0.75m high, 0.6m wide and 0.4m deep (Figure 6). K2 was in the northern part of the east wall; it measured 0.75m high, 0.5m wide and 0.45m deep (Figure 7). K3 was in the eastern portion of the north wall; it measured 0.5m high,



**Figure 1** The full-view of the location of the Western Zhou tombs at Shigushan in Baoji (NE–SW).

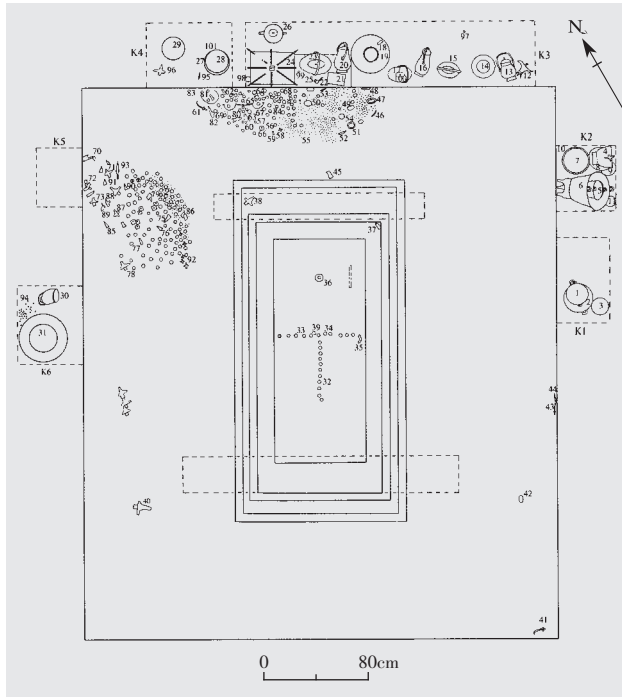

**Figure 2** The plan of Shigushan M3.

1, 2, 5, 11, 28 and 81. Bronze *ding*-tripods; 3, 7–10 and 27. Bronze *gui*-tureens; 4, 38, 40, 43, 67, 68, 70–79, 85, 87–91 and 96. Bronze *ji*-helbards; 6. Bronze *yan*-steamer; 12. Bronze *jue*-cup; 13, 15, 17, 20, 23 and 30. Bronze *you*-wine jars; 14. Bronze *zun*-vessel; 16. Bronze vase; 18 and 45. Bronze axes; 19. Bronze *lei*-wine jar; 21 and 25. Bronze *jin*-stands; 22 and 100. Bronze ladles; 24. Bronze *yi*-wine vessel; 26. Bronze *he*-pitcher; 29. Pottery *li*-cauldron; 31. Bronze *pan*-basin; 32, 33, 42, 46–52, 54, 56 and 84. Bronze bubble-shaped ornaments; 34 and 39. Bronze ornaments; 35 and 36. Jade objects; 37. Bronze bell; 41, 44, 61, 62, 82 and 86. Bronze *ge*-dagger axes; 53. Bronze chisel; 55, 69 and 94. Cowries; 57. Bronze buckle; 58, 59, 83 and 92. Bronze rein joints; 60, 63, 64 and 80. Bronze horse forehead ornaments; 65. Bronze bow-shaped object; 66. Bronze horse bit; 93. Bronze spearhead; 95 and 101. Bronze adzes; 97 and 99. Shell ornaments; 98. Bronze *zhi*-cup.

2.3m wide and 0.45m deep (Figure 8). K4, located in the western part of the north wall, measured 0.55m high, 0.56m wide, and 0.5m deep (Figure 9). K5, located in the northern part of the west wall, measured 0.5m high, 0.45m wide and 0.35m deep. K6 was located slightly north of the center of the west wall; it was 0.35m high, 0.7m wide, and 0.5m deep (Figure 10). Apart from K5, all of the recesses contained grave goods.

The wooden burial receptacles were located in the



**Figure 3** The full-view of Shigushan M3 (top is north).

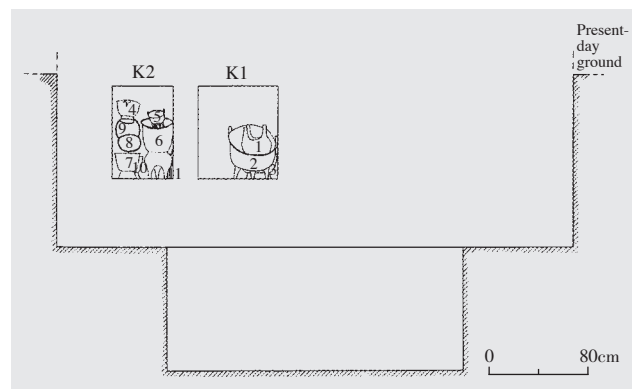

**Figure 4** The east section of Shigushan M3.

1, 2, 5 and 11. Bronze *ding*-tripods; 3, 4 and 7–10. Bronze *gui*-tureens; 6. Bronze *yan*-steamer.

center of the grave and inside the ledges. Based on the traces of decayed matter, there appeared to have been two outer coffin chambers and one inner coffin. The outermost coffin chamber measured 1m high, 2.7m long, and 1.3m wide; the innermost of the outer coffin chambers was 2.3m long and 0.98m wide. The planks forming the outer coffin chambers were approximately 6cm thick. One inner coffin, measuring 1.8m long and 0.7m wide, had been placed inside the innermost of the outer coffins. The roof of this inner coffin bore a T-shaped design made up of small bronze bubble-shaped ornaments.

One set of human remains, already decayed into powder,



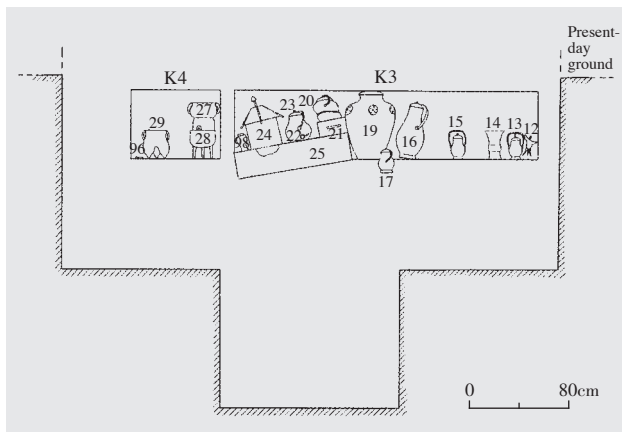

**Figure 5** The north section of Shigushan M3.

12. Bronze *jue*-cup; 13, 15, 17, 20 and 23. Bronze *you*-wine jars; 14. Bronze *zun*-vessel; 16. Bronze vase; 19. Bronze *lei*-wine jar; 21 and 25. Bronze *jin*-stands; 22. Bronze ladle; 24. Bronze *yi*-wine vessel; 27. Bronze *gui*-tureen with square stands; 28. Bronze *ding*-tripod; 29. Pottery *li*-cauldron; 96. Bronze *ji*-helbard; 98. Bronze *zhi*-cup.



**Figure 6** The bronze *ding*-tripods and *gui*-tureen put in K1 in situ.

was discovered inside the inner coffin. A straight strip of bone trace, potentially the remains of a decayed leg bone, was discovered in the north-central portion of the area inside the inner coffin. Based on this, it was supposed that the occupant was placed with head toward the south.



**Figure 7** The bronze *yan*-steamer, *ding*-tripods and *gui*-tureens put in K2 in situ.



**Figure 9** The bronze *ding*-tripod, *gui*-tureen with square stand and pottery *li*-tripod put in K4 in situ.



**Figure 8** The bronze wine vessels orderly put in K3 in situ.



**Figure 10** The bronze *pan*-basin and *you*-wine jar put in K6 in situ.

### Artifacts recovered

1. Bronze items: A total of 101 bronze pieces were unearthed (not including fragments extracted from plaster casting wraps). These included ritual vessels, weapons, chariot and horse fittings, etc. Most were situated inside the recesses on the grave walls.

Bronze *ding*-tripod with bird clan emblem and “Fu Jia” inscription, one piece (M3:1). It has a slightly contracted mouth, an out-bending rim, upright ears, a slightly bulging belly, a round bottom, and three pillar-shaped legs. A band of confronted *kui*-dragon designs appears below the rim; the legs bear raised flanges and *taotie*-animal mask designs. All of the ornamentation appears against a background of whorl patterns. A bird clan emblem and the two characters “*Fu jia* 父甲 (Father Jia)” are cast into the inside rim. The vessel is 33.3cm high; its mouth is 26.8cm in diameter. The vessel weighs 9.2kg (Figures 11 and 12).

*Ding*-tripod with flanges, one piece (M3:2). It has a slightly contracted mouth, an out-bending rim, attached ears, a slightly bulging belly, and three hoof-shaped legs. The belly and legs of the vessel bear flanges with openwork decoration. The inner belly contains rounded hollows at the junction points with the three legs. Six *kui*-dragon designs with curled tails appear below the rim; the middle of the vessel belly is decorated with vertical ridges, while the lower portion bears banana-leaf patterns. The legs bear *taotie*-animal mask designs atop paired bowstring patterns. On the outer bottom, Y-shaped casting fins can be seen among the three legs. The vessel is 44cm high and its mouth is 34cm in diameter. The vessel weighs 15.9kg (Figures 13 and 14).

*Gui*-tureen with square base, one piece (M3:27). It has a flared mouth, a contracted neck, a bulging belly, a round bottom and a square base. The ears attached to the neck and belly of the vessel bear animal-head designs in high relief and hanging “earlobes.” Between the ears, the neck of the vessel bears a series of animal-head designs interspersed with small *kui*-dragon designs and

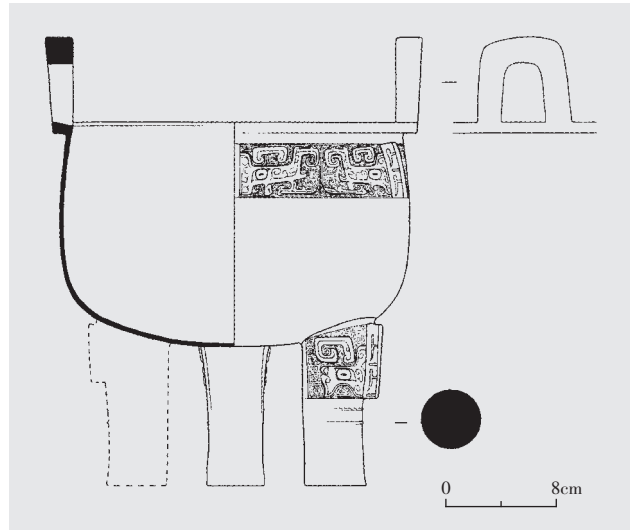

**Figure 11** Bronze *ding*-tripod with bird clan emblem and “Fu Jia” inscription (M3:1).



**Figure 12** Bronze *ding*-tripod with bird clan emblem and “Fu Jia” inscription (M3:1).

swirl roundels, all bounded by two bowstring patterns. The vessel belly is decorated with vertical ridges. At the junction point between the base and the belly, two bowstring patterns enclose a series of swirl roundels and four-petal patterns. The four faces of the base bear phoenix designs in high relief, with beaks in the shape of elephant trunks, human faces, rabbit ears, flower-shaped combs and long wings; scale patterns appear on their beaks and the lower parts of their bellies. A smaller phoenix bird design appears standing below each phoenix. A bronze adze (M3:101) was found from the base of this *gui*-tureen. The vessel is 23.8cm high; its mouth is 19.6cm in diameter. The vessel weighs 4.73kg (Figures



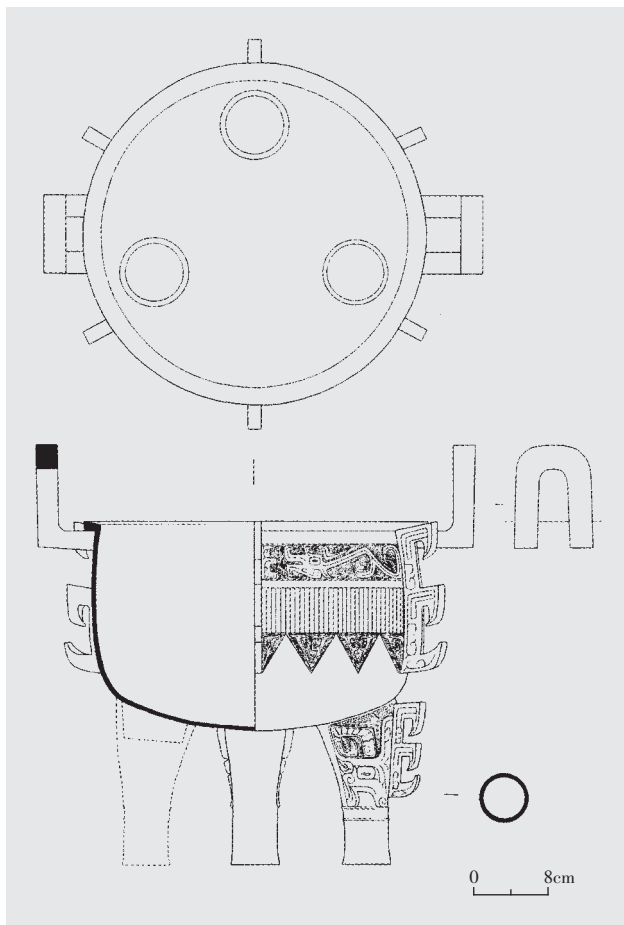

Figure 13 Bronze *ding*-tripod with flanges (M3:2).



Figure 14 Bronze *ding*-tripod with flanges (M3:2).

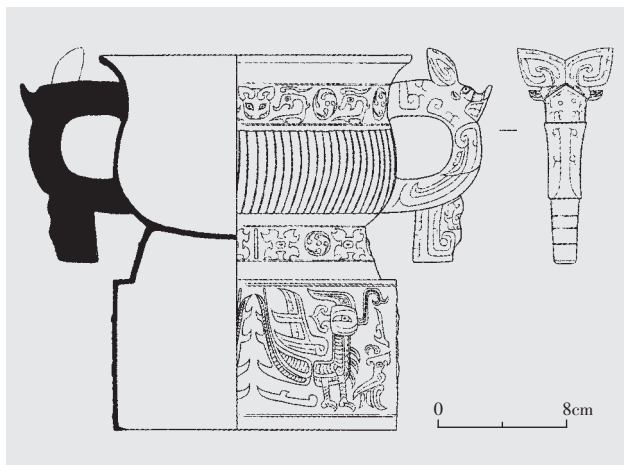

Figure 15 Bronze *gui*-tureen with square base (M3:27).



Figure 16 Bronze *gui*-tureen with square base (M3:27).

15 and 16).

*Gui*-tureen with double ears, one piece (M3:10). It has a flared mouth, a round bottom, and a ring foot. Symmetrically placed ears with animal masks and hanging “earlobes” are attached to the mouth and belly of the vessel. Below the rim, in the places exactly the middle between the ears, are two symmetrical animal

mask designs flanked by interspersed phoenix and swirl roundel patterns. The belly of the vessel is decorated with diagonal checks and studs. Four groups of *kui*-dragon decorations appear on the ring foot. The vessel is 19.6cm high; its mouth is 27.0cm in diameter. The vessel weighs 5.22kg (Figures 17 and 18).

*Jin*-stand no. 1 (M3:25) is a hollow, rectangular

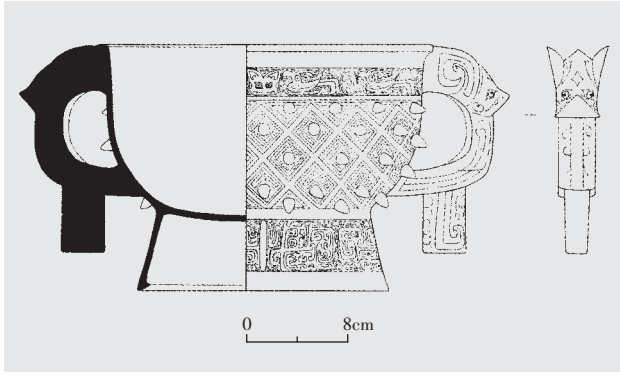

**Figure 17** Bronze *gui*-tureen with double ring-shaped handles (M3:10).



**Figure 18** Bronze *gui*-tureen with double ring-shaped handles (M3:10).

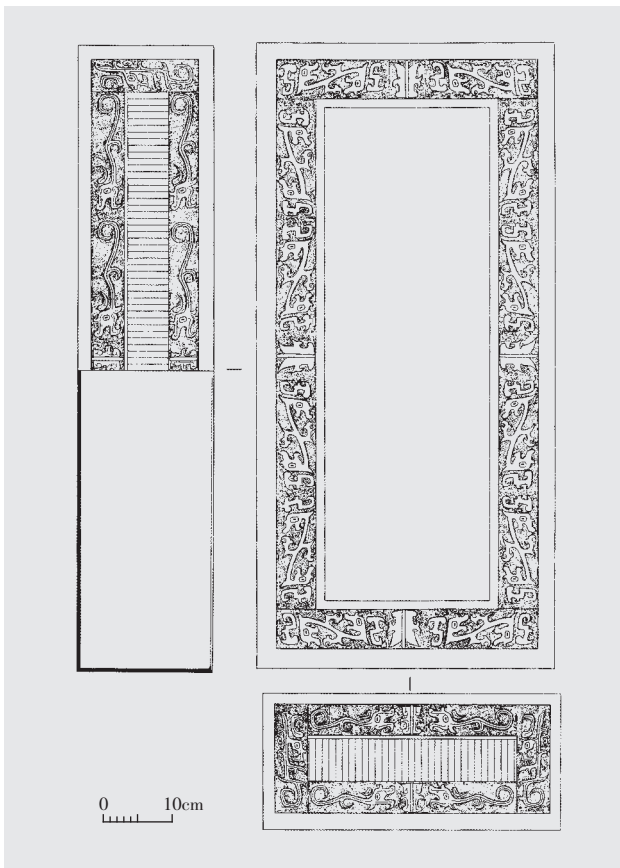

**Figure 19** Bronze *jin*-stand no. 1 (M3:25).

stand for vessels. The edges of its four side surfaces are unadorned, while the center portions bear patterns of straight ridges, which is framed by rectangles composed in turn of *kui*-dragon motifs against a background of *leiwen*-square spiral patterns. Flanges appear in the exact middle of the upper and lower rims of the long sides. The *kui*-dragons have raised heads, wide mouths, outward-turned lips, round eyes, bent bodies and coiling tails. The right and left sides of the frames contain stylized *kui*-dragon designs oriented vertically. Flanges also appear in the exact middle of the upper and lower portions of



**Figure 20** Bronze *jin*-stand no. 1 (M3:25).

the frames on the short faces of the stand, with coiling-tailed *kui*-dragon designs on either side. The right and left sides of these frames likewise contain stylized *kui*-dragon designs oriented vertically. The top of the stand is decorated with a frame containing *kui*-dragon designs on a *leiwen* background. Flanges appear in the exact middle of the two long sides of the frame, with two backward-facing *kui*-dragon designs on each side of the flanges. Additional flanges appear in the exact middle of the short sides of the frame, with a backward-facing *kui*-dragon design to each side of each flange. All of these designs combine to form a rectangular frame pattern, the rectangular surface inside of which is unadorned. The *jin*-stand is 20.5cm high, 94.5cm long and 45cm wide; it weighs 41.80kg (Figures 19 and 20).

*Jin*-stand no. 2 (M3:21) is rectangular. A raised oval appears in the center of the upper surface, surrounding which is a rectangular frame composed of *kui*-dragon patterns. The four sides have rectangular holes in the centers surrounded by rectangular decorative frames consisting of two-headed *kui*-dragons for their upper

portions, vertical *kui*-dragon designs for the two sides, and central flanges flanked by confronted phoenix designs for their lower portions. The *jin*-stand is 10.3cm high, 17.4cm long and 14.4cm wide; it weighs 2.06kg (Figures 21 and 22).

“Hu” *you*-wine jars, two pieces. These two vessels are oval in shape, with swing handles and lids. The vessels have interlocking rims, sagging bellies, round bottoms and ring feet. The necks bear sets of symmetrically placed, ring-shaped ears that are linked to the handles. Four flanges appear along the two sides and the midlines of the vessels and their lids. The two sides of the flanges are inscribed with patterns of short lines and spirals. The lids have cylindrical grips in the top center crowned with knobs in the shape of flower bud; the six petals of each bud bear cicada designs, while the cylindrical grip stems bear four-petal patterns. The cylindrical grip is surrounded by a ring of straight ridges, and again ringed by eight phoenix figures. Paired ears in the shape of ox horns are placed symmetrically on the outside of each lid, bearing ox-head and cicada designs in relief; the upper portions of the ears are inscribed with ox-head and serration designs. Eight phoenix designs adorn the upper portion of each vessel’s neck, while the shoulders bear a set of straight ridges. Each vessel belly bears four large phoenix designs in high relief, depicted prone, with smaller phoenixes squatting beneath their tail feathers in opposing direction. The upper portion of each ring foot likewise bears eight phoenix designs. Animal masks in high relief adorn the two ends of each handle; the outside of each handle is decorated with four sets of backward-facing *kui*-dragon designs, while the inside is inscribed with stylized *kui*-dragon patterns. Hu you A (M3:23) has the same inscription, the character *hu* 𠄎, cast into both the vessel body and its lid. The vessel is 50cm in full height; its mouth is 14.5 and 18.2cm in minor and major diameters. The vessel weighs 17.85kg (Figures 23 and 24).

“Ran Fu Yi” *you*-wine jars, two pieces. These two vessels are identical in shape and decoration, but differ in size. They are oval-shaped, with swing handles and lids. The vessels have interlocking rims, sagging bellies, round bottoms, and circular feet. The lids are bordered with pearl-string patterns enclosing *leiwen*-square spiral pattern; flower bud-shaped knobs appear atop the lids, each decorated with cicada patterns. The handles are in the shape of ropes, looped at the ends through half-ring-shaped ears on the shoulders of each vessel. The shoulder portion of each vessel bears a band of decorations in two groups, each consisting of an animal mask design in the middle, with *leiwen* bordered by pearl-string patterns to both sides. The upper portion of each foot bears two rings of bowstring design. The sample M3:13 bears identical inscriptions, both reading “Ran Fu Yi 𠄎 (冉) 父乙”, cast into both the vessel body and its lid. The vessel is 32cm in full height; its mouth is 11.7 and 14.6cm in minor and major diameters. The vessel weighs 4.92kg (Figures 25 and 26).

“Hu” *yi*-wine vessel, one piece (M3:24). This vessel has a lid in the style of a hipped roof. The vessel is

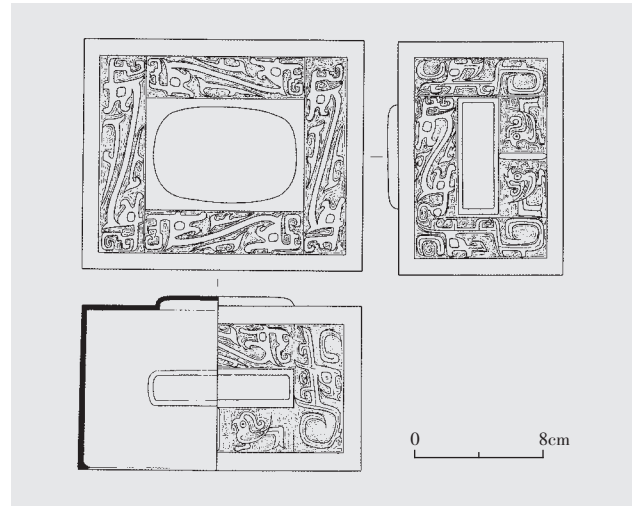

Figure 21 Bronze *jin*-stand no. 2 (M3:21).



Figure 22 Bronze *jin*-stand no. 2 (M3:21).

rectangular, with a contracted mouth, a straight belly, a flat bottom, and a high hollow foot. Flanges with openwork appear along the four corners and central lines of the vessel. The top of the lid and the neck, belly, and foot of the vessel each bear four registers of décor against a background of *yunleiwen*-circular and square spiral patterns. The flanges on the four corners of the lid bear inverted animal mask designs; the upper portion is decorated with *kui*-dragon designs, and the upper portions of the animal mask patterns on the two triangular slopes bear stylized triangular *kui*-dragon patterns. The grip on the top center of the lid is in the shape of square pillar with a gable roof; the two slopes of the roof of the grip are decorated with animal mask designs and the two gables are decorated with stylized triangular *kui*-dragon patterns. Animal head-shaped ears extend from the centers of the four faces of the vessel neck; each of these animal heads has a pair of palm-shaped horns on the top and *kui*-dragon designs to its two sides. The four faces of the



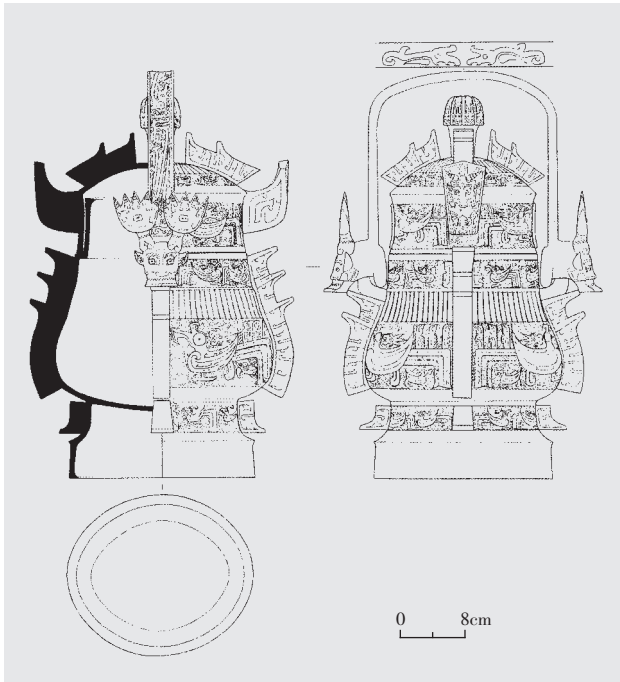

Figure 23 Bronze “Hu” you-wine jar A (M3:23).

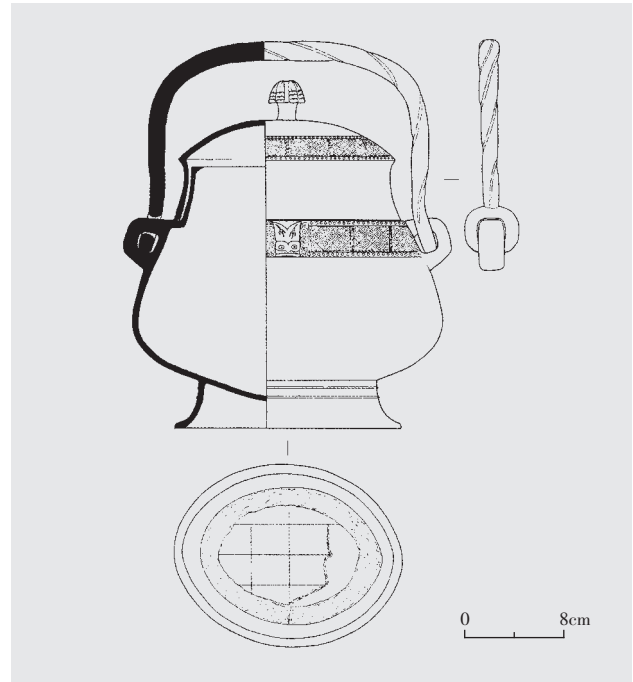

Figure 25 Bronze “Ran Fu Yi” you-wine jar (M3:13).



Figure 24 Bronze “Hu” you-wine jar A (M3:23).



Figure 26 Bronze “Ran Fu Yi” you-wine jar (M3:13).

vessel belly bear large animal mask designs with flanges in their centers. *Kui*-dragon designs appear to the two sides of the flanges in the centers of the four faces of the vessel foot; a vertical gap appears below each flange. The vessel body and lid bear identical inscriptions consisting of the character “Hu 𠩺”. The vessel is 63.7cm in full

height; the vessel mouth is 35.4cm long and 23.5cm wide. The vessel weighs 35.55kg (Figures 27 and 28).

“Fu Gui” *zun*-vessel, one piece (M3:14). This vessel has a flared mouth; a cylindrical, slightly bulging belly; and a high ring foot. Both belly and foot bear four flanges with horizontal lines on their two sides. A pair of raised



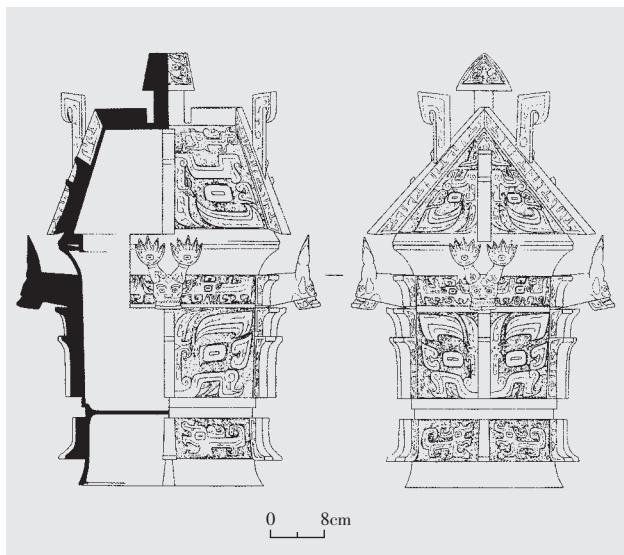

Figure 27 Bronze “Hu” yi-wine vessel (M3:24).



Figure 28 Bronze “Hu” yi-wine vessel (M3:24).

bowstring patterns appears on the lower neck. The belly is adorned with four pairs of *kui*-dragon patterns each pair of which are confronted each other to form an animal mask design. The foot of the vessel bears four pairs of *kui*-dragon designs with elephant trunks, also confronted each other to form animal mask designs; a smaller *kui*-dragon design appears above the trunk in each group. The designs on both belly and foot appear against a background of *leiwen*-square spiral patterns. The inner wall of the ring foot bears an inscription with eight characters in three lines: “□□商 / 用作父癸 / 彝 [XX Shang therewith makes a

vessel for Father Gui.]” The vessel is 27.3cm in full height; the mouth is 20.5cm in diameter. The vessel weighs 2.75kg (Figures 29:1 and 30).

“Fu Jia” vase, one piece (M3:16). This vessel has an interlocking rim, a sagging belly, a round bottom and a ring foot. Its rope-shaped handle connects with a pair of ring-shaped ears placed symmetrically on the neck of the vessel. The crown and face of the lid bear a decorative band consisting of four groups of linked, hook-shaped whorls and two round eyes, bounded on the top and bottom by pearl-string patterns. The foot area likewise bears a band of linked, hook-shaped whorl decorations bounded by pearl-strand patterns. Identical inscriptions consisting of the three characters “Fu Jia X 父甲▲” are cast into the vessel body and lid. The vessel is 42.2cm in full height; the mouth is 10.4cm in diameter. The vessel weighs 6.51kg (Figures 29:2 and 31).

“Wan” *yan*-steamer, one piece (M3:6). This cooking vessel consists of a linked *zeng*-steamer and *li*-cauldron. The *zeng* portion has a flared mouth with curved rim; upright, rope-shaped ears; a slanting belly above a contracted waist that links it with the *li*-cauldron below; and an interior grate separates them. The *li*-cauldron portion has a bulging belly, a split crotch and three pillar-shaped legs. A square protuberance appears on the interior grate opposite a ring on the inside wall of the belly; the grate also has five cross-shaped slots for steaming. The mouth of the *li*-cauldron below the grate bears three small triangular projections to hold the grate. A decorative band below the rim of the *zeng*-steamer portion consists of three groups of *taotie*-animal mask designs with a small flange in the center, the two sides of which bear confronted *kui*-dragon designs. The belly of the *li*-cauldron bears elephant head designs; the bottom of the belly is sooted. An inscription consisting of the

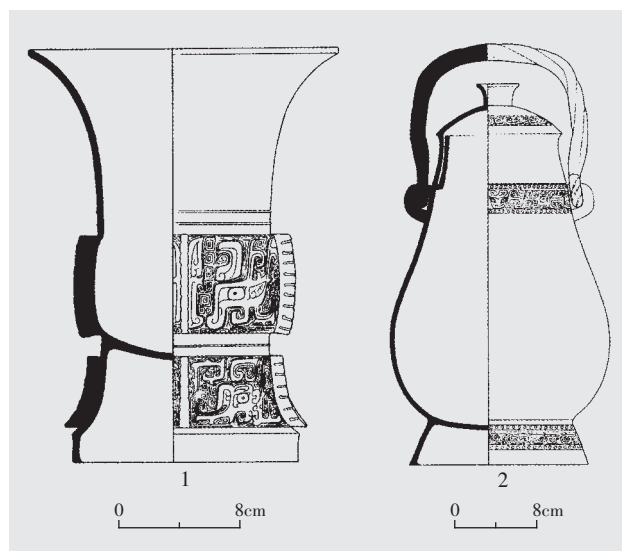

Figure 29 Bronze wine vessels.

1. “Fu Gui” *zun*-vessel (M3:14); 2. “Fu Jia” vase (M3:16).



Figure 30 Bronze “Fu Gui” *zun*-vessel (M3:14).

character “*Wan* 萬” is cast into the inside of the vessel rim. The full height of the vessel is 47.5cm; the diameter of the vessel mouth is 28-29cm. The vessel weighs 7.93kg (Figures 32 and 33).

“*Ya Qiang Fu Yi*” *lei*-wine jar, one piece (M3:19). This vessel has a flared mouth, a contracted neck, rounded shoulders, a bulging belly, a convex bottom and a ring foot. The lid of the vessel is low dome-shaped with an interlocking rim; its surface is decorated with four swirl roundels. Two rings of bowstring patterns encircle the vessel neck. The vessel shoulders bear a pair of symmetrically placed ears in the shape of ox heads holding rings in the mouth, as well as six swirl roundels and a ring of sunken bowstring pattern encircling the shoulder area. An ox head-shaped knob appears on one side of the lower belly, forming an approximate triangular arrangement with the pair of ears on the vessel shoulders. The inscription “*Ya Qiang Fu Yi* [ 亞羌 (亞羌) 父乙 ]” is cast into the inside rim. The vessel measures 50cm in full height; the mouth is 18.2cm in diameter. The vessel weighs 14.08kg (Figures 34 and 35).

“*Ran*” *he*-pitcher, one piece (M3:26). This pitcher has a flared mouth, a contracted neck, a bulging belly, a split crotch, and three pillar-shaped legs. It has a tube-shaped spout and a handle that is chained to the vessel lid. The lid itself bears a decorative band of linked, hook-shaped whorls bounded by pearl-string patterns, as well as a grip on top with a two-headed dragon design. The handle bears an animal mask design, while the spout is decorated with cicada patterns. The vessel shoulders are decorated in the same manner as the lid. Triangle patterns



Figure 31 Bronze “Fu Jia” vase (M3:16).

formed from paired lines extend from the crotch of the vessel to the tops of the legs. A clan emblem consisting of the single character *ran* 冉 (冉) is cast into the belly of the vessel just below the handle. The vessel measures 28.5cm in full height; the mouth is 10.6cm in diameter. The vessel weighs 2.55kg (Figures 36 and 37).

*X Gui pan*-basin, one piece (M3:31). This basin has a flared mouth, an outward-bending rim, a round bottom and a ring foot. The foot and the area below the rim each bear a band of décor bordered by pearl-string patterns. The band below the rim contains three animal mask patterns, each with two *kui*-dragon patterns to either side. The décor band on the foot also comprises three registers, each with a central flange flanked by two *kui*-dragon designs on either side. Spiral patterns form the background in both bands. The inner bottom of the vessel belly has an inscription consisting of the four characters “*Qu Chen X Gui* [ 曲 (曲) 臣 癸 ]” cast into it. The vessel is 13.6cm high and 36.6cm in diameter at the mouth; it weighs 3.8kg (Figures 38 and 39).

“*Fu Gui*” *jue*-cup, one piece (M3:12). This *jue*-cup has a flared mouth, a long spout, a slightly bulging belly, a round bottom, three conical legs, and a pair of umbrella-shaped pillars atop the rim, the top of each of which bears a swirl roundel design. The half ring-shaped handle of the cup carries an animal head design. The belly bears four eye designs against *leiwen*-square spiral patterns as background. An inscription of five characters in two lines, reading “*Qu Chen X Fu Gui* [ 曲 (曲) 臣 癸 / 父癸 ]”, is cast into the belly below the handle. This *jue*-cup measures 21cm high and weighs

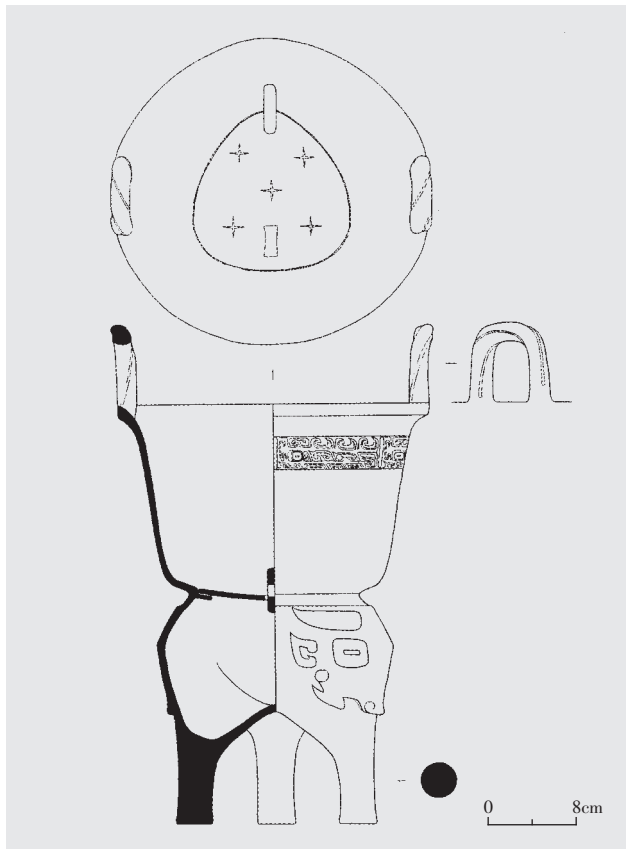

Figure 32 Bronze “Wan” yan-steamer (M3:6).

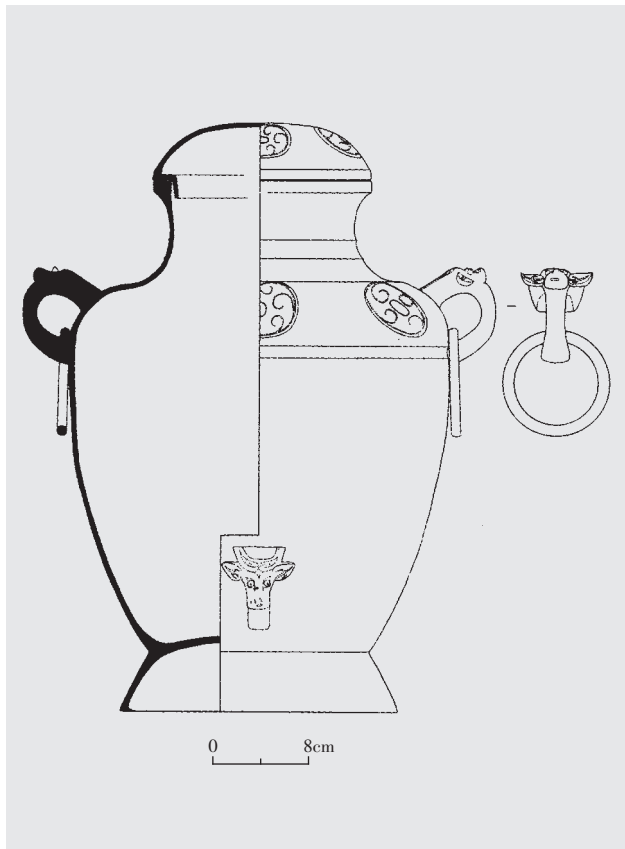

Figure 34 Bronze “Ya Qiang Fu Yi” lei-wine jar (M3:19).



Figure 33 Bronze “Wan” yan-steamer (M3:6).



Figure 35 Bronze “Ya Qiang Fu Yi” lei-wine jar (M3:19).



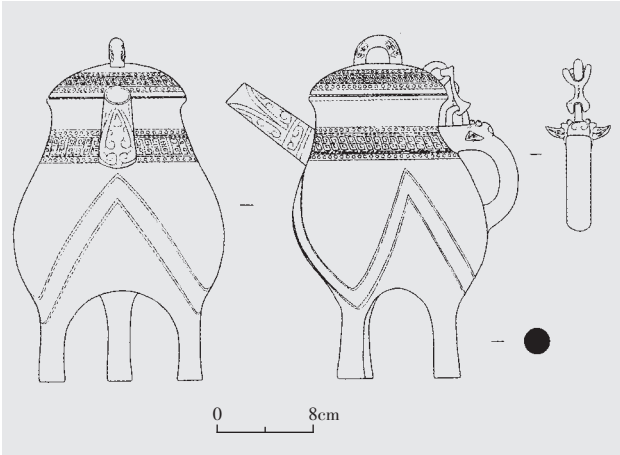

Figure 36 Bronze “Ran” *he*-pitcher (M3:26).



Figure 37 Bronze “Ran” *he*-pitcher (M3:26).

0.8kg (Figures 40:1 and 41).

*Zhi*-cup, one piece (M3:98). It is oval in shape with a flared mouth, a contracted neck, a bulging belly and a ring foot. The neck of the vessel bears banana-leaf patterns; two flanges appear below the neck, flanked by phoenix designs against a background of spiral patterns. The belly is decorated with vertical ridges. The upper portion of the foot likewise bears two flanges flanked by phoenix designs against a background of spirals. The vessel is 13.5cm high; the mouth measures from 7.4-8.2cm in minor and major diameters. The vessel weighs 0.45kg (Figures 40:2 and 42).

2. Pottery vessels, only a high-necked *li*-cauldron with pouched legs (M3:29). Made of sandy grayish-brown pottery, it has a flared mouth and a high, contracted neck;

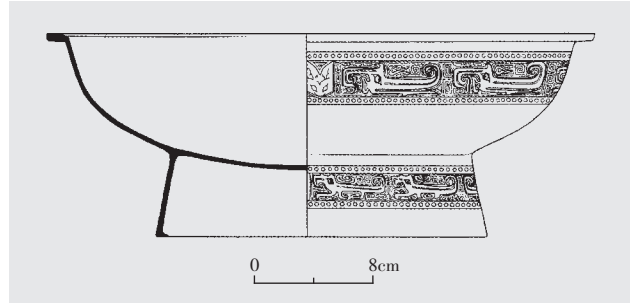

Figure 38 Bronze “X Gui” *pan*-basin (M3:31).



Figure 39 Bronze “X Gui” *pan*-basin (M3:31).

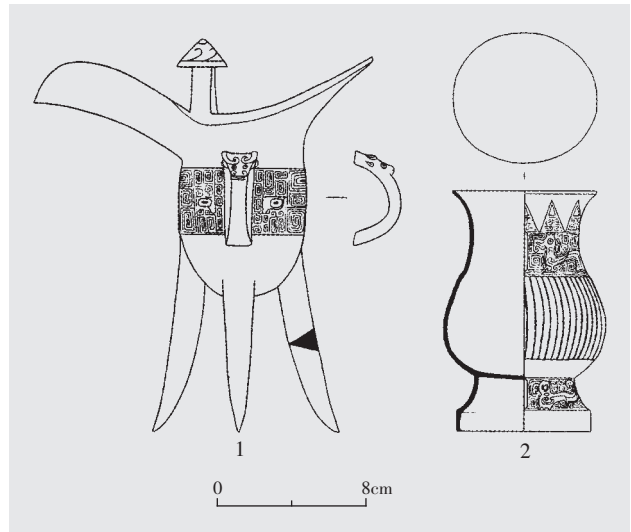

Figure 40 Bronze wine cups.

1. “Fu Gui” *jue*-cup (M3:12); 2. *Zhi*-cup (M3:98).

the three pouched legs are relatively plump, with round and tapered ends. A pair of ears is situated outside the rim. The entire body of the *li*-cauldron is decorated with cord patterns, but the band below the rim is brightly polished. The base of the crotch bears pricked patterns. The vessel is 12.8cm tall; the mouth is 12cm in diameter (Figure 43).



Figure 41 Bronze “Fu Gui” *jue*-cup (M3:12).



Figure 42 Bronze *zhi*-cup (M3:98).



Figure 43 Pottery high-necked *li*-cauldron with pouted legs (M3:29).

## Conclusions

Based on a comparative analysis of the high-necked *li*-cauldron with pouted legs and of the bronze items, the grave goods found in tomb M3 could date to the late Shang Dynasty at the earliest; to the Shang-Zhou transition; or to the early Western Zhou at the latest. Considering the shape and other characteristics of the grave as well, M3 should date to the early Western Zhou Dynasty.

The ritual bronzes unearthed from the tomb are well preserved and form complete assemblages. Their large size and fine craftsmanship amply illustrate the grand and honored status of the tomb occupant. M3 may be considered a classic example of a high-level aristocratic tomb.

Judging from the artifacts recovered from the tomb, the occupant belonged to the Hu 户 clan, indicating that the Western Zhou cemetery at Shigushan was that of a family of Jiang Rong ethnic group belonging to the Hu clan.

The initial discovery of the Hu clan family cemetery has filled in a gap in the historical records and enriched the distribution area of Shang and Zhou settlements in the Baoji region. Meanwhile, the shapes and décors of the *jin*-stands, the Hu *you*-wine jar, the Hu *yi*-wine vessel and other items are in many respects extremely similar to those of items of the same types unearthed at Daijiawan. These two cemeteries, situated across from each other on opposite banks of the Wei River, share the same date. Further research is called for on the relationships between the two.

## Postscript

The original report published in *Kaogu yu wenwu* 考古与文物 (Archaeology and cultural relics) 2013. 1: 1–24 with 38 illustrations and 10 plates was authored by Junshe Liu 刘军社, Hao Wang 王颢, Yihua Xin 辛怡华, Zhankui Wang 王占奎, Mingke Hao 郝明科, Xiaomei Wang 王小梅 and Yan Ding 丁岩. The revised version was prepared by Junshe Liu and translated into English by Paul Nicholas Vogt 侯昱文.